



The Toolroom Company

ET 30-40 SERIES LARGE CAPACITY FRYER 828 CONTROL

MAINTENANCE MANUAL



TABLE OF CONTENTS

1.0 – SAFETY INFORMATION

General Safety	4
1.01 Mechanical Safety	5
1.02 Electrical Safety	6

2.0 – BASIC INSTALLATION

2.1 WHERE TO PLACE YOUR MACHINE

2.11 Foundation	7
2.12 Environmental Conditions	7

2.2 UNLOADING YOUR MACHINE 7

2.3 RECEIVING YOUR MACHINE 7

2.4 UNPACK AND PLACE YOUR MACHINE 8

2.5 PRIOR TO THE ARRIVAL OF THE TECHNICIAN

2.51 Installation Safety Instructions	8
2.52 Cleaning & Lubricating Machine	8
2.53 Line Voltage Check	8
2.54 Electrical Precautions	9

2.6 LEVELING THE MACHINE

2.61 Leveling Procedure	10
-------------------------------	----

3.0 – GENERAL INFORMATION

3.1 MAINTENANCE SCHEDULE CHART 11

3.2 MACHINE COMPONENTS

3.21 Axis Lubrication System	12
3.22 Electrical System	12
3.23 Pneumatic System	13
3.24 Spindle	13
3.25 Flood Coolant System	14

3.3 BASIC MACHINE PROCEDURES

3.31 Set Axis Home Position	15
3.32 Check Axis Backlash	16
3.33 Adjusting Backlash Compensation	16
3.34 Spindle Endplay Adjustment	17
3.35 Check Drive Belts	18

4.0 - 828 CONTROL

4.1 ACCESSING MACHINE PARAMETERS 19

4.2 ACCESSING THE SOFTWARE VERSION..... 19

4.3 REVERT TO THE FACTORY SET PASSWORD 19

4.4 ADJUSTING INPUT VOLTAGE PARAMETERS 20

4.5 M-CODES 21

4.6 ALARMS

4.61 Siemens Alarms	22
4.62 Fryer PLC Alarms and Descriptions	22
4.63 Clearing an Alarm	23

4.7 WORKING WITH FILES

4.71 File Types	23
4.72 Back-Up A 828 Archive File to A USB Stick	23

4.73 Reloading an Archive File	24
4.74 Backing Up Tool Data on the 828 Control	24
4.8 ADDING A SOFTWARE OPTION TO AN 828 CONTROL	25
4.9 SET UP NETWORK DRIVE IN AN 828	27
5.0 - TURRET	
5.1 ALIGNING THE TURRET	29
5.2 DUPLOMATIC ERROR ALARM CODES	30
6.0 - DRAWINGS AND PARTS LIST	
6.1 828 CONTROL ELECTRICAL PANEL LAYOUT & PARTS LIST	32
6.2 828 FRONT CONSOLE LAYOUT & PARTS LIST	34
6.3 BASE CASTING ASSEMBLY DRAWING & PARTS LIST	35
6.4 ELECTRICAL CABINET DRAWING & PARTS LIST	37
6.5 HEADSTOCK DRAWING & PARTS LIST	39
6.6 HEADSTOCK WITH 6" BORE - DRAWING & PARTS LIST	43
6.7 HEADSTOCK LUBRICATION SYSTEM DRAWING & PARTS LIST	47
6.8 X AXIS ASSEMBLY DRAWING & PARTS LIST	48
6.9 Z AXIS ASSEMBLY DRAWING & PARTS LIST	50
6.10 SADDLE DRAWING #1 & PARTS LIST	52
6.11 SADDLE DRAWING #2 & PARTS LIST	54
6.12 SHEET METAL ASSEMBLY DRAWING & PARTS LIST	55
6.13 DOOR ASSEMBLY DRAWING & PARTS LIST	58
6.14 TAILSTOCK ASSEMBLY (END VIEW) DRAWING & PARTS LIST	60
6.15 TAILSTOCK ASSEMBLY (SIDE VIEW) DRAWING & PARTS LIST	61

SAFETY INFORMATION- LATHES

READ BEFORE INSTALLING OR OPERATING

NOTE: THIS MACHINE IS AUTOMATICALLY CONTROLLED AND MAY START AT ANY TIME.



All CNC machines contain hazards from rotating parts, belts and pulleys, high voltage electricity, noise, and compressed air. When using CNC machines and their components, basic safety precautions must always be followed to reduce the risk of personal injury and mechanical damage.

It is the machine owner's responsibility to make sure all personnel who are involved in installation and operation of this machine are thoroughly acquainted with the procedures and safety instructions provided herein *BEFORE* they perform any actual work.

Only Fryer factory-trained service personnel should troubleshoot and repair the equipment.

Do not modify or alter this equipment in any way without first consulting Fryer Machine. Any modification or alteration of could lead to personal injury and/or mechanical damage and/or void your warranty.



1. Use the emergency stop button to stop all machine motion in the event of an emergency.
2. Use the feed hold button to stop axis movement during normal operation.
3. Before operating switches, always check that they are the right ones.
4. Do not change parameters, voltages and other electrical settings unless directed by an authorized service technician. If such changes are unavoidable follow the directions provided by the technician carefully.
5. The best defense against injuries on a turning machine is to be alert. Never initiate a machine function unless you completely understand what the function will cause the machine to do.

6. Keep machine and area around it clean and well lighted. Never allow chips, coolant, or oil to remain on the floor. Do not leave loose objects on or around machine.
7. Use appropriate eye and ear protection while operating the machine. ANSI-approved impact safety goggles and OSHA-approved ear protection are recommended to reduce the risks of sight damage and hearing loss.
8. Keep all loose clothing, hair, jewelry away from the machine and from contacting the spindle
9. Gloves are easily caught in moving parts. Take them off before turning on the machine.
10. Always wear safety shoes with steel toes and oil-resistant soles.
11. Do not paint, alter, deface, or remove any warning plates from the machine. Replacement plates are available from Fryer Machine Systems.
12. Keep flammable liquids and materials away from the work area and hot chips.
13. Coolant and oils can make surfaces on the machine slippery. They can also present an electrical hazard if the machine has power on. Therefore, do not stand on any part of the machine at any time.
14. Keep material in the spindle from extending beyond the rear edge of the spindle.
15. Check for damaged parts and tools before operating the machine. Any part of a tool that is damaged should be properly repaired or replaced. Do not operate the machine if any component does not appear to be functioning correctly.
16. Improperly clamped parts machined at high speeds/feeds may be ejected and puncture the safety door. Machining oversized or marginally clamped parts is not safe.
17. To avoid turret damage, ensure that tools are properly aligned when loading tools and that boring bars and facing tools do not protrude behind the back of the faceplate.
18. Windows must be replaced immediately if damaged or severely scratched – contact the factory for replacement panels.
19. Do not attempt to operate the machine before all of the installation instructions have been completed.
20. Be sure to review the Maintenance section of this manual for instructions to keep your machine running properly.

1.01 Mechanical Safety

1. Always press emergency stop when the machine is not in use.
2. Never operate the machine with any cover or shield open or removed.
3. Never reach into the work area when the spindle is turning or if the machine is in automatic mode.
4. Put the machine in manual mode and be sure last programmed function has been completed before reaching inside of the work area.
5. The functions of the machine make it impossible to eliminate all pinch points. Be particularly aware of the following pinch points:
 - a. Spindle and chuck rotation
 - b. Indexing of turret and tools
 - c. Carriage and cross-slide movement
 - d. Tailstock movement, both quill and body
6. Do not operate machine without axis motor covers or axis way covers in place.
7. Report any loose, worn, or broken parts to your supervisor. The same action should be taken if any unusual noise or machine action occurs.

8. The electric components are protected from normal moisture resulting from humidity, use of water base soluble, such as coolant, etc. **DO NOT**, however, use water hose to clean the machine or the area around it.
9. Never touch a machine control device or electrical component when your hand is wet.
10. Never clean up chips while the machine is running or is in automatic mode.
11. Do not manually deburr workpieces being rotated under power.
12. At the end of the workday the machine should be placed in "EMERGENCY STOP MODE"
13. When restarting a machine after it has been shut down always assume it has been altered. Recheck all phases of the job as though you were running the first piece.
14. Never touch spindle start or spindle jog control until hands, feet, and body are well clear of the work area.
15. Never extend an unsupported bar out of the rear of the spindle or hydraulic cylinder. Doing so can cause the bar to bend or break resulting in damage or injury.
16. If your turning machine has a bar feeder interfaced to it keep yourself and others away from the exit end of the bar feeder when the machine is running.

1.02 Electrical Safety

1. **WARNING:** Electrical enclosures contain high voltage. Disconnect equipment from power source before opening cabinets.
2. Before replacing a fuse, switch off the machine.
3. **Immediately turn off power if:**
 - Power problems develop
 - In the event of electrical storms.
 - Ambient temperatures exceed 105 degrees Fahrenheit (40 degrees C)
4. The electrical power must meet the specifications in this manual. Attempting to run the machine from any other source can cause severe damage and will void the warranty.
5. The electrical panel should be closed and locked at all times except during service
6. When the main circuit breaker is on, there is high voltage throughout the electrical panel and some components operate at high temperatures. Therefore, extreme caution is required.
7. Do not reset a circuit breaker until the reason for the fault is investigated.
8. Never service the machine with the power connected.

2.0 BASIC INSTALLATION

2.1 WHERE TO PLACE YOUR MACHINE

Thank you for choosing Fryer Machine Systems. You have purchased a high quality, custom crafted machine tool designed and built to provide years of trouble-free service. To ensure that your machine is properly installed we ask that you review the following information prior to the shipment of your machine.

2.11 Foundation

Your foundation must be a minimum 6"(150mm) thick concrete slab floor and should be placed on a single slab with no seams. Be sure to leave space around the machine for leveling components and access to the electrical cabinet.

If your floor does not meet these specifications, contact the factory for further recommendations.

Install the machine on the first or second floor. Take the stress of ceiling and foundation into careful consideration to ensure that the machine load can be offset.

2.12 Environmental Conditions

Generally, the machine will be installed in the following conditions. However, these may change over a period of time or in response to seasonal changes.

- Supply voltage: +/- 10% of voltage listed on serial number tag.
- Source frequency: ± 2 Hz of frequency listed on serial number tag
- Temperature effects dimensional accuracy, therefore, ambient temperatures should not exceed 105 degrees Fahrenheit. Also avoid exposing the machine to direct sunlight or heat rays which can change the environmental temperature.
- Relative Humidity: Less than 80% (Temperature changes should not cause condensation)
- Atmosphere: Free from excessive dust, fumes, corrosive gases, and salt
- Avoid exposing the machine to abnormal vibration.

2.2 UNLOADING YOUR MACHINE

Fryer machines are shipped on skids designed for forklift offloading. Be sure your forklift is rated for the proper weight of the machine.

Note: If you are using a crane for offloading, please contact the factory in advance for instructions as damage can occur if supported in the wrong locations.

2.3 RECEIVING YOUR MACHINE

NOTE: If you have a door that is less than 8' wide x 10' high, please contact the factory prior to shipment so that we can make sure your machine is packaged to fit into your door openings.

1. Fryer machines are carefully packed to avoid damage in transit; however, we ask that you **UNWRAP AND INSPECT YOUR MACHINE AS THOROUGHLY AS POSSIBLE PRIOR TO SIGNING THE BILL OF LADING.** If a digital camera is available, pictures should be taken before the machine is moved further. Pictures should be sent to service@fryermachine.com.
2. Place the machine in its location and complete inspection. If there is any damage to your machine, Fryer should be notified immediately. This will enable us to provide replacement parts before the service technician arrives install the machine.
3. If you have any questions about any of these installation instructions or other questions about your new Fryer Machine Systems machine, please call the Fryer Service Department and one of our trained technical staff will be happy to assist you.

2.4 UNPACK AND PLACE YOUR MACHINE

To make certain that your machine installation goes smoothly, it is important that the following items are completed **prior** to the arrival of the Fryer authorized service technician. This will ensure that our technician is able to provide you with the maximum amount of training during his allocated time with you.

1. Have your rigger move the machine to the operating location, remove it from the skid and install on ALL leveling pads.
2. Remove all packaging material and thoroughly clean the machine and inspect for hidden damage.
3. Remove all large assemblies from skids and stage next to machine to facilitate ease of assembly.
4. Install leveling pads and level machine. Level with a precision level, using the leveling screws and pads provided with the machine.

2.5 PRIOR TO THE ARRIVAL OF THE TECHNICIAN

2.51 Installation Safety Instructions

Initial start-up of the machine must be performed by a Fryer Machine Systems authorized service technician.

2.52 Cleaning & Lubricating Machine

All protective coatings (cosmoline) must be removed before using the machine.

Be cautious when selecting a suitable cleaning agent. Paraffin applied with a clean brush will soften the protective coating. The protective coating can then be removed with clean rags.

- WD-40 or a similar product is recommended for cleaning the machine. Do not use gasoline or any other flammable solution to clean the machine.
- Clean all exposed ways of the bed and saddle.

2.53 Line Voltage Check

Line voltage must be $\pm 10\%$ of the voltage listed on the serial number tag.

**INITIAL POWER-UP SHOULD ONLY BE PERFORMED BY
A FRYER TECHNICIAN OR FACTORY AUTHORIZED
REPRESENTATIVE.**

2.54 Electrical Precautions

Wiring

1. Ensure that all local electrical codes are met.
2. Do not connect to the power distribution panel any power cables for devices that can cause line noise, such as welders and high frequency quenching machines.

Grounding

You should always refer to your local electrical code to be sure you are grounding to code. Generally, use a grounding wire with a cross section of more than 14 mm and a resistance to ground of less than 100 ohms. This wire size should be greater than AWG (American Wire Gauge) No. 5 and SWG (British Legal Standard Wire Gauge) No.6.

Generally, the machine should be grounded to a separate grounding rod. If an independent ground cannot be provided for the machine, prepare the ground connection as follows:

1. Connect a single conductor to its own grounding terminal. This will avoid possible serious accidents resulting from ground currents that might otherwise flow in the NC machine if a peripheral device should malfunction.
2. Be careful when using concrete reinforcing rods as grounding points. These reinforcing rods often are used to ground equipment because they usually offer a resistance to ground of less than 100 ohms. In doing so, make the connection as follows: (This also applies to connecting ground wires to regular grounding terminals)
3. Do not use the same grounding reinforcing rod or grounding terminal for other devices since this could lead to line noise such as produced electric welders and high frequency quenching machines.
4. Use a grounding terminal with an adequate electrical performance rating and which is durable.
5. A separate grounding wire should be used, one whose length is as short as possible.
6. Check the resistance to ground by actual measurement.
7. This should measure less than 100 ohms if the single device is connected to its own grounding rod.

Desirable Independent Grounding: Earth resistance: Less than 100 ohms **Common Grounds:**

Resistance to ground = $100 / \text{the number of devices connected to the grounding } (\Omega)$

NEVER GROUND EQUIPMENT IN SERIES!

Connection of Power Line

NOTE: Electrical installation should only be completed by a qualified electrician.

1. Make sure that the incoming power is compatible with the requirements of the machine tool (voltage, amperage, phasing). All this information can be found on the machine's serial number tag.
2. Power wires, grounding and over-voltage protection should comply with the local electrical code.
3. **DO NOT** connect if the incoming power is different from the power requirements of the machine. Contact a qualified electrician.

2.6 LEVELING THE MACHINE

Before using the machine, it will be necessary to accurately level it.

1. Screw the leveling bolts (with nut) into the holes in the base of the machine. Set a leveling pad under.
2. Please prepare the following tools to adjust machine level:
 - a. One spirit level (0.0005"/ft. or 0.013mm/1000mm accuracy)
 - b. Two adjustable wrenches
3. Clean the bed way and cross slide surfaces thoroughly and set the spirit level on the cross slide parallel to one axis rotating it 90deg alternating between X-Axis and Z-Axis.
4. Move the machine in the Z-Axis as close to the head stock as possible and center the cross slide in the X-Axis. Start using the corresponding leveling feet to get the level to read zero making sure to rotate the level to check both X and Z.
5. Now move the machine toward the tail stock slightly and again use the leveling feet to make the levels read zero. Repeat this step for the entire Z-Axis travel again making sure to rotate the level to check both X and Z.
6. Repeat steps 4 & 5 until machine is leveled to within 0.001"/ft. (0.08mm/1000mm) in both directions throughout the entire Z-Axis travel.
7. Lock the nuts on the leveling bolts, and re-check to see whether the level of machine is still correct. Repeat as necessary until machine level is obtained with leveling bolts locked.

After initial installation, check the level once a week for the first month, then check monthly thereafter.

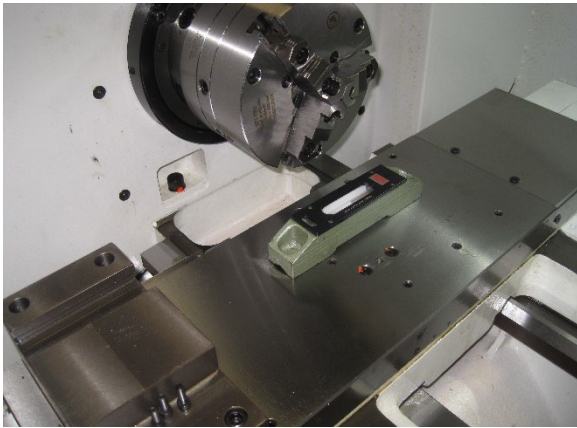

X-AXIS

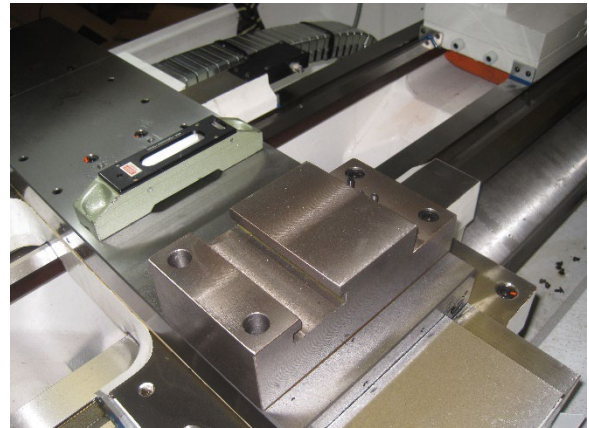

Z-AXIS

3.0 GENERAL INFORMATION

3.1 Maintenance Schedule

CAUTION: Always turn the machine off before performing maintenance.

MAINTENANCE ITEM	RECOMMENDED	Daily	Weekly	As Req'd.	6 Mo	Yearly
Check pressure gages for proper readings	90-125 PSI	X				
Check that machine components and sliding parts have proper lubrication		X				
Check condition of covers for damage or excessive gasket wear		X				
At the end of the day, remove and dispose of chips	Use of brush or vacuum is recommended. Do not use air as it can push chips into ways and ballscrews.	X				
Drain air/water separation			X			
Check wipers for damage			X			
Check coolant level			X			
Check headstock oil level			X			
Check turret oil level (if option is installed)	Mobilub HD Plus 80W90 or equivalent oil		X			
Change coolant	Blasocut BC-40 NF-PL or Equivalent oil			X		
Fill lube pump	Mobil Vactra No. 2, Amoco Waytac No. 68 or Equivalent			X		
Fill air regulator oil for auto shift	Mobil Almo Break-Free Synthetic Air Tool oil (5W-10W) or Equivalent			X		
Check servo cabinet & console fans, clean filters	Frequency should be determined by type of material being cut and number of hours the machine is running.			X		
Check machine level					X	
Check ball screw endplay					X	
Check gibs					X	
Check backlash					X	
Check belt / coupling tension						X
Replace servo cabinet and console filters	Purolator A23465					X
Change headstock (spindle) oil	Mobil DTE ISO VG-32 Hydraulic Oil or Equivalent Oil (VG-22 for ET-18 model)					X
Change hydraulic system oil (if option is installed)	Mobil DTE ISO VG-32 Hydraulic Oil or Equivalent Oil					X
Change turret oil (if option is installed)	Mobilub HD Plus 80W90 or Equivalent oil					X

3.2 MACHINE COMPONENTS

3.21 Axis Lubrication System

- The automatic way lube system is controlled by the PLC in the control. The system only pumps way oil



when the spindle and axes are moving. If there is no machine movement the pump will not pump unnecessary oil. This method greatly reduces way lube usage and keeps oil out of the machine coolant sump and prevents fouling.

- If the machine has been unused for more than 48 hours press the blue pushbutton on the side of the lube tank for approximately 30 seconds to pump oil to the ways. The pressure gage on the tank will indicate if it is working properly.
- If the system detects low way lube it will display the following message in the control: 700016 - WAY OILER PRESSURE FAULT

3.22 Electrical System

- Schematics (1) – The Electrical and Pneumatic Schematics are inside electrical cabinet
- Cabinet Filter Type (2) – Purolator A23465 or equivalent
- Check Filter Interval - Weekly
- Change Filter Interval – As Required (depending on environment)



3.23 Pneumatic System

- Schematic – See Pneumatic Schematic in electrical cabinet (see previous page)



- Pneumatic List / Pressure Settings
 - Main Supply – 90-125 PSI at 5 CFM
 - Air Gun
- Lubrication Requirements – Mobil Almo break free synthetic air tool oil 5W-10W or equivalent
- Check Lubrication Interval – Weekly – Add as needed

3.24 Spindle / Gearbox

Thermal expansion of the machine components can jeopardize machining accuracy. To prevent this condition always warm the machine up.

SPINDLE WARM UP – Warm up the machine by running it for 10 to 20 minutes at about half or one-third the maximum speed in the automatic operation mode.

This automatic operation program should cause each machine component to operate allowing you to check their operation.

SPINDLE DUTY RATING – Follow the duty rating outlined below

- If it is required for the spindle to run continuously (24 hours a day), the spindle must not run above 80% of the maximum RPM.
- If it is required for the spindle to run at maximum RPM, the spindle must not run more than 2 hours straight. After 2 hours of run time at maximum RPM, the spindle must be slowed down to 50% of the maximum RPM for at least 30 minutes before running at the maximum RPM again.

3.25 Flood Coolant System

The flood coolant system consists of a submersible flood pump mounted in the base casting of the machine. The flood line runs up the back of the column and through the Z-axis cable track. It splits at a y-fitting in the headstock where it runs to two separate lengths of loc-line.

- The submersible flood pump is mounted behind the access panel shown below.
- The sump can be drained for coolant changes by using a wet vacuum.



3.3 MACHINE PROCEDURES

3.31 Set Axes Home Positions

PROCEDURE TO BE PERFORMED BY QUALIFIED PERSONNEL ONLY

The 828 control comes standard with absolute encoders which generally do not require homing. However, if you have an issue with the battery or the machine is not turned on for an extended length of time the machine may need to be re-homed according to the following procedure. In addition, if an axis motor is removed or there is an issue with a motor coupling or pulley / belt assembly, one or more axes may need to be re-homed.

•Refer to Section 4.1 for directions to access parameter screens.

1. Press **MENU SELECT**
2. Select **SETUP**
3. Select **MACHINE DATA**
4. Select **AXIS MD**
5. Select **SEARCH**
6. Enter **34210 [0]** in the search field (This will read **ENC_REFP_STATE**)
7. Select **OK**
8. Select the proper axis with the **AXIS + AND AXIS –**
9. Change the parameter **34210 [0] to 0** for an axis with a motor encoder
10. Change the parameters **34210 [0]** and **34210 [1] to 0** for an axis with a scale
11. Press **INPUT**
12. Cycle power to machine leaving it off for a minimum of 30 seconds
13. **Take extreme caution now as the machine can be crashed!**
14. Line up the home markers for all axes that need to be homed
15. Press the **E-STOP** button to turn off the servos
16. Press **MENU SELECT**
17. Select **SETUP**
18. Select **MACHINE DATA**
19. Select **AXIS MD**
20. Select **SEARCH**
21. Enter **34210 [0]** in the search field (This will read **ENC_REFP_STATE**)
22. Select **OK**
23. Select the proper axis with the **AXIS + AND AXIS –**
24. Make sure Parameter **34210 [0]** and **34210 [1]** (if axis has a scale) **are set to 0**. If it is not, it is probable that the wrong axis is selected.
25. Change the parameter **34210 [0] to 1** for an axis with a motor encoder
26. Change the parameters **34210 [0]** and **34210 [1] to 1** for an axis with a scale
27. Press **INPUT**
28. Turn the feed rate override all the way down
29. Pull the **E-Stop** button out
30. Select **RESET**
31. Press **HOME RETURN** (should say Jog Ref at the top of the screen)
32. For a lathe, press **CYCLE START**
33. When done make sure parameter **34210 [0]** shows **2** for all axes (axis with motor encoder)

3.32 Check Axis Backlash

Tools Required: 0.0001" resolution dial indicator, control handwheels handwheel

- Set the indicator along the axis which is being measured. The needle should be in contact with a flat machined surface and the base on a stable, fixed point. See the pictures below which illustrate the setup for the X and Z axes.
- Using the remote handwheel, move the axis in one direction either positive or negative until the indicator is loaded by 0.002".
- Zero the indicator.
- Move the axis in the same direction by 0.005".
- Reverse the direction of the axis by 0.005".
- The additional amount that is needed to reach zero after the 0.005" reverse in direction is the backlash measured.
- This shows the loss of motion in the axis from the ballscrew and linear guide rails. Backlash compensation can be adjusted according to the procedure outlined below in *Section 3.33*.

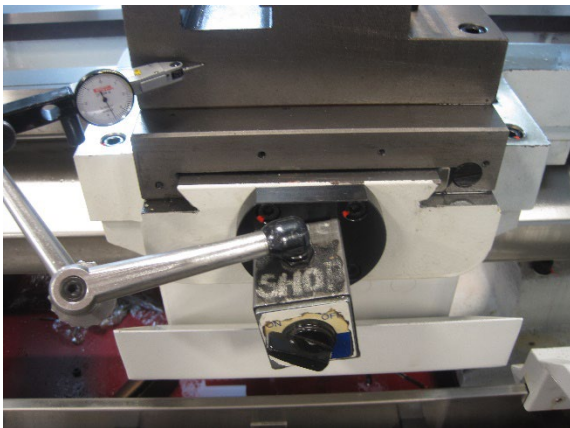

X-AXIS



Z-AXIS

3.33 Adjusting Backlash Compensation

PROCEDURE TO BE PERFORMED BY QUALIFIED PERSONNEL ONLY

Refer to Section 4.1 for directions to access parameter screens.

- Press **MENU SELECT**
- Select **SETUP**
- Select **MACHINE DATA**
- Select **AXIS MD**
- Using **AXIS+ AND AXIS-**, select the correct axis
- Select **SEARCH**
- Enter **32450 [0]**
- Adjust the backlash on each axis
- Select **SET MD ACTIVE (cf)**
- Select **RESET (po)** to reboot the control

3.34 Spindle Endplay Adjustment

PROCEDURE TO BE PERFORMED BY QUALIFIED PERSONNEL ONLY

1. Remove headstock sheet metal and lid. With the auto-shift air pressure off, set the gearbox in neutral by rotating the shifter shaft manually.

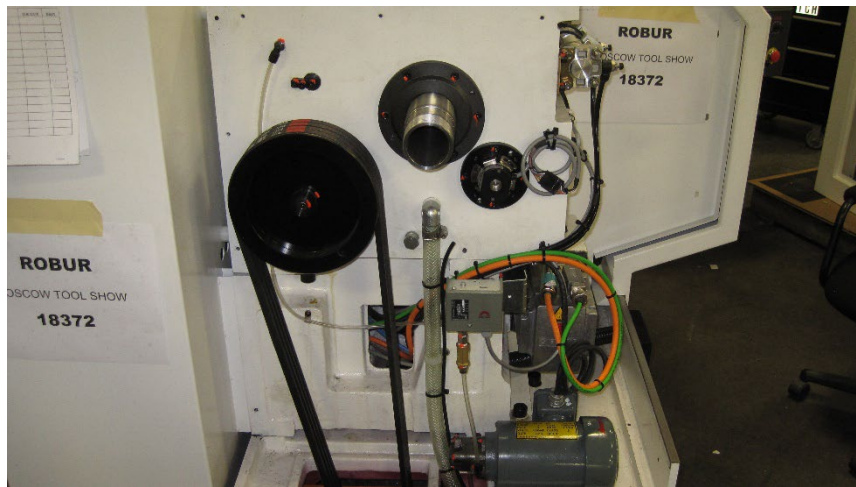
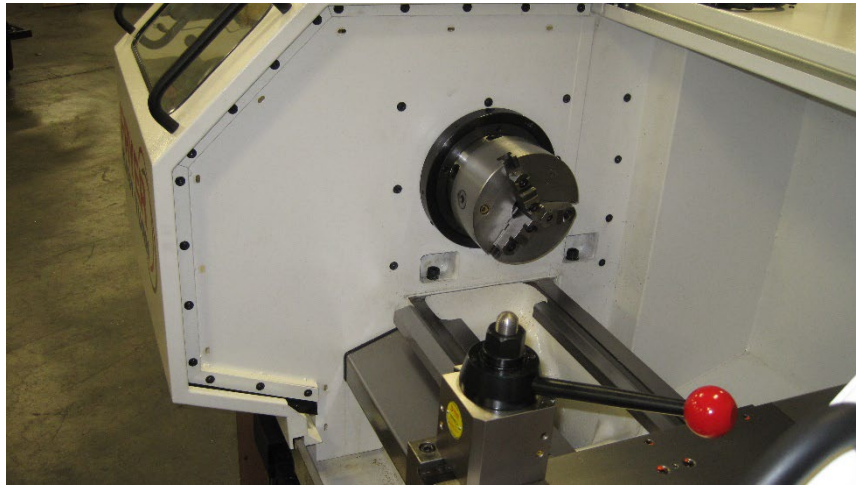

2. Mark the spanner rings with a white line to indicate the original position on the shaft. Loosen set screws on the thrust spanner ring.

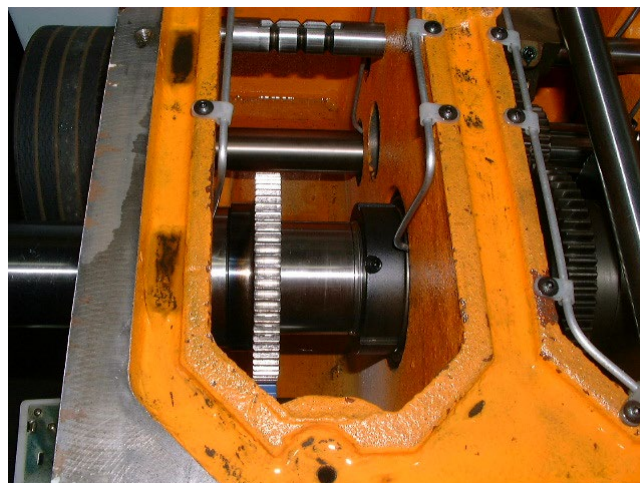

Encoder Drive Gear

Thrust Spanner

3. Using an aluminum or brass drift, tighten the spanner ring a $\frac{1}{4}$ " of movement at a time from the white mark. Rotate the spindle by hand and note how easy it is to move. Check the endplay by placing a long shaft in the chuck or spindle bore.

- Put in neutral, feel the spindle movement, tighten until you feel some resistance then back up slightly.

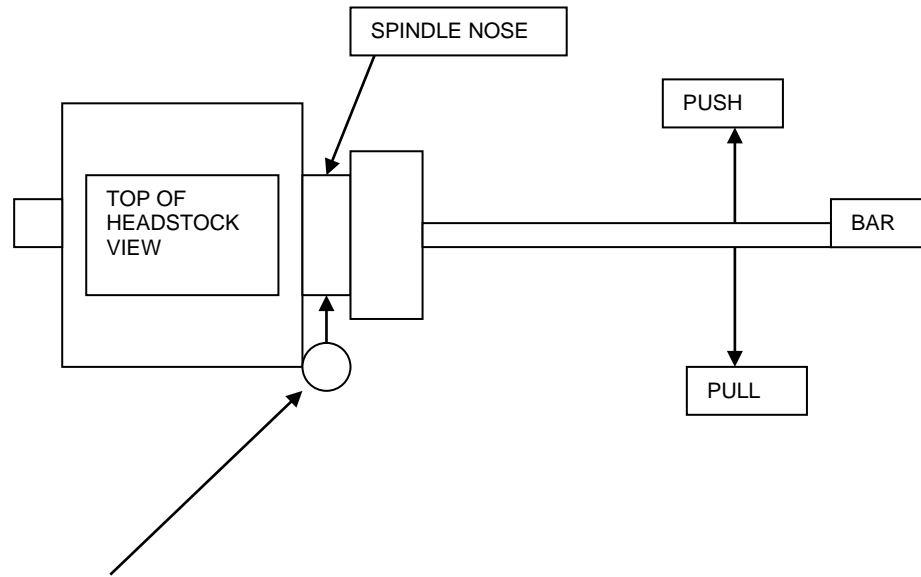

- Place the indicator on the side of the spindle nose. Measuring the endplay by checking the side load on the *tapered roller bearings* is more accurate than trying to get and axial movement. Pull and push and note the indicator. Normal endplay is MAX .0002". The spindle will have slight drag when adjusted right. If you hear a rattle, like loose roller cages, it is most likely too loose. While in neutral, manually spin the spindle, if it freewheels, then the thrust is most likely loose. Run it, let it warm up and cool down, readjust and check the endplay. Repeat several times until it is certain that the bearings are seated properly.
- Replace all sheet metal.

3.35 Check Spindle Motor Belts

- The axis motors are connected to the ballscrews via pulley driven belts. Belts should be checked for excessive wear and proper tension at least every 6 months.
- Once you have gained access to the belts, inspect them for any visible signs or wear or damage. Once the belts are considered acceptable, check each belt for proper tension.
- Belt tension is adjusted by loosening the slotted motor plate and sliding the motor-plate assembly to tighten or loosen the belt as required. Double check all hardware is properly tightened once the belt tension is correct.
- After the inspection is complete and any adjustments made, re-install the belt covers.



4.1 ACCESSING MACHINE PARAMETERS

PROCEDURE TO BE PERFORMED BY QUALIFIED PERSONNEL ONLY

 **WARNING**

Malfunctions of the machine as a result of incorrect or changed parameter settings

As a result of incorrect or changed parameterization, machines can malfunction, which in turn can lead to injuries or death.

- Protect the parameterization (parameter assignments) against unauthorized access.
- Handle possible malfunctions by taking suitable measures, e.g. emergency stop or emergency off.

1. Press **MENU SELECT**
2. Select **SETUP**
3. Select **MACHINE DATA**
4. Available folders: **GENERAL MD / CHANNEL MD / AXIS MD**

4.2 ACCESSING THE SOFTWARE VERSION

To find out the version of the software you are running on your 828 control:

1. Press **MENU SELECT**
2. Select **DIAGNOSIS**
3. Select **VERSION**
4. The Software Version number is on the first line and will read: **"V###.## + SP ## + HF ##"**

4.3 REVERT TO THE FACTORY SET PASSWORD

PROCEDURE TO BE PERFORMED BY QUALIFIED PERSONNEL ONLY

1. Press **MENU SELECT**
2. Select **SETUP**
3. Select **SET PASSWORD**
4. Enter the password: **SUNRISE**
5. Press **OK**
6. The lower part of the screen should now read "Current Access Level: Manufacturer"

4.4 ADJUSTING INPUT VOLTAGE PARAMETERS

PROCEDURE TO BE PERFORMED BY QUALIFIED PERSONNEL ONLY

The Siemens control will shut itself off if the line voltage is more than 10% different than the voltage set in the control. You must adjust the parameter to match your line voltage to the machine.

The following alarms may occur when this happens:

1. Power 1 overvoltage
2. Axis drive faults
3. DC link voltage overvoltage

The first step to accurately measure your line voltage. There are two ways to do this.

- Measure the incoming line voltage across all three legs with a voltmeter. Average your readings and write down the value.

- OR -

- Read the line voltage from the control, follow the following steps:
 - **MENU SELECT** key
 - **SETUP** key
 - **INFEED PARAMETER** key
 - Find **r25[0]** = and write down the voltage value in this parameter.

- Now you have the proper line voltage value to enter in the control.

Follow the steps below:

- Press E-stop
- **MENU SELECT** key
- **SETUP** key
- Press \wedge (up arrow hard key next to machine hard key)
- **DRIVE SYSTEM** key
- **SUPPLY** key
- **POWER DATA** key See screen below:

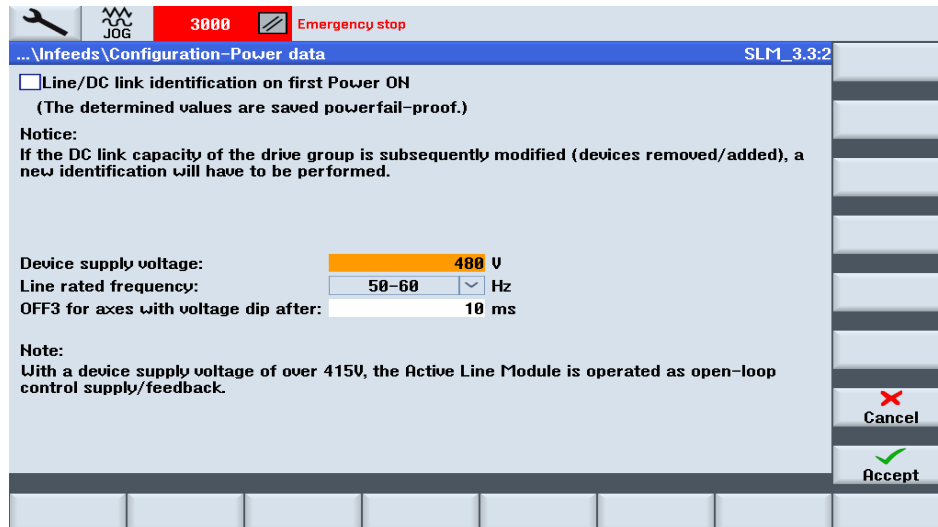

- Scroll down to the **Device Supply Voltage** field like in the screen shot above. Enter the line voltage value you obtained in the previous steps, press enter
- Press **ACCEPT** key
- There will be a message that states, "Confirm You Want to Change the Parameter", Press **YES** key to accept the change.

4.5 M-CODES

An M code in CNC programming controls miscellaneous machine functions, including starting and stopping specific actions or programs.

M00	Program stop
M01	Optional program stop(button on panel must be on
M02	End of Program
M03	Spindle clockwise
M04	Spindle counterclockwise
M05	Spindle stop
M07	Spray mist / air blast
M08	Flood coolant
M09	Coolant off (M07 and M08)
M11	Miscellaneous M-code function on
M12	Miscellaneous M-code function off
M13	Live tool spindle clockwise
M14	Live tool spindle counterclockwise
M15	Live tool spindle off
M17	Reference turret to tool #1
M19	Main spindle orient
M20	Main spindle collet or chuck open (with ID-OD grip switch in OD)
M21	Main spindle collet or chuck close (with ID-OD grip switch in OD)
M22	Tailstock chuck
M23	Tailstock chuck open
M24	Steady rest close
M25	Steady rest open
M26	Tailstock extend (toward Headstock)
M27	Tailstock retract
M29	Rigid Tapping with Live Tools
M30	End of program
M90	Parts catcher catch position
M91	Parts catcher retract stand by position
M33	C axis Brake On
M34	C axis Brake Off
M46	Barfeed cycle-edit barfeed program for alterations
M70	C axis Mode Enable

NOTE: M-codes may change depending on options the machine is equipped with

4.6 ALARMS

An alarm will be displayed once a fault occurs.

! Warning: *If you do not heed an alarm that is issued and do not resolve the cause of the alarm, it can present a hazard to the machine, the work piece, the saved settings, and in certain circumstances, may cause injury.*

4.61 Siemens Alarms

1. If a familiar alarm number / description appears carefully check the machine and resolve the cause of the alarm.
2. If you are unfamiliar with the alarm in question, proceed to the alarm list as follows:
 - a. Press **MENU SELECT**
 - b. Select **DIAGNOSTICS**
 - c. Select **ALARM LIST**
3. *Once "**ALARM LIST**" has been selected, press **HELP** key and additional information will be provided on the control screen.

4.62 Fryer PLC Alarms and Descriptions

There are certain PLC alarms in the 700000 range which are not in the **HELP** screen. These are FRYER Machine specific alarms that are for optional equipment installed on the machine. The alarms are listed below:

700000 HEADSTOCK OIL PRESSURE FAULT
700001 LOW WAY LUBE
700002 TURRET THERMAL OVERLOAD
700004 GEARSHIFT FAULT-CHECK AIR PRESSURE
700005 LOW AIR PRESSURE FAULT
700006 LOW HYDRAULIC PRESSURE FAULT
700007 C AXIS HANDWHEEL ACTIVE (X AXIS OFF)
700008 LIVE TOOL DRIVE GEAR NOT ENGAGED!!
700009 CHUCK OR COLLET MUST BE CLOSED TO RUN SPINDLE
700010 HIGH PRESSURE COOLANT ALARM
700012 TURRET NOT INDEXED OR CLAMPED!
700013 TAILSTOCK NOT CLAMPED!
700014 SPINDLE OUT OF GEAR
700015 TAILSTOCK DRAG ARM NOT AT REST POSITION!
700016 WAY OIL PRESSURE SWITCH
700032 CONTOUR HANDWHEEL ACTIVE
700033 DEPRESS HOLD THEN STOP TO STOP SPINDLE DURING AUTO CYCLE
700034 TAILSTOCK NOT CLAMPED
700035 REFERENCE RETURN: PRESS START
700037 DOOR IS OPEN CLOSE DOOR AND PRESS CYCLE START
700038 TOOL SETTER ACTIVE
700039 PART PROBE ACTIVE
700042 TURRET NOT FULLY CLAMPED

4.63 Clearing an Alarm

1. Carefully check the machine according to the description given in the alarm. Clarification of the alarm codes can be found by using the **HELP** as described above.
2. Resolve the cause of the alarm.
3. Press **RESET**
4. Certain alarms will require a reboot of the control to clear.

4.7 WORKING WITH FILES

4.71 File Types

- **NC** archive contains the machine **PARAMETERS**
- **PLC** archive contains the **LADDER LOGIC** for the machine functions
- **DRV** archive contains the **AXIS DRIVE SETTINGS**

4.72 Back-Up An 828 Archive File to A USB Stick

- For a download of the machine archive to a USB , press these three keys at the same time on the control:
CTRL + ALT + S
 - This will create a complete standard Easy Archive (**.ARD**) on a **USB**.
-

If a specific file or additional files need to be backed up to a **USB**, do the following:

PROCEDURE TO BE PERFORMED BY QUALIFIED PERSONNEL ONLY

1. Select the **MENU SELECT**.
2. Select the **STARTUP**.
3. Press the **SYSTEM DATA** key. The data tree will open.
In the data tree, select the required files from which you want to generate an archive.
4. Press the **ARCHIVE** and **GENERATE ARCHIVE** keys.
5. The **GENERATE ARCHIVE: SELECT STORAGE LOCATION** window opens. Select the **USB** location for archiving.
6. Save the file as serial number of machine and the file name (i.e., for drive archive: "25123DRV")
7. Enter a name and press the **OK** key. The directory is created below the selected folder.
8. Press the **OK** key.
9. Select the format archive **ARD** for 828, enter the desired name and press the **OK** key to archive the file/files.
A message informs you if archiving was successful.
10. Press the **OK** key to confirm.
11. An archive file in the **.ARD** (828) format type is created in the selected directory.

*Note: When backing up an entire machine you should generate an individual file for NC, PLC, Drive, and HMI. When that step is completed, you should generate an archive for all these together.

4.73 Reloading an Archive File

PROCEDURE TO BE PERFORMED BY QUALIFIED PERSONNEL ONLY

NOTE: Set the password protection to "Current Access Level: Manufacturer". Refer to Section 4.3 above.

1. Select the **PROGRAM MANAGER** key.
2. Press the **ARCHIVE** and **READ IN ARCHIVE** keys.
3. Select the archive storage location (i.e., **USB**) and position the cursor on the required archive.
4. Note: When the option is not set, the folder for user archives is only displayed if the folder contains at least one archive.

OR

5. Press the **SEARCH** key and in the search dialog, enter the name of the archive file with file extension **.ARD** if you wish to search for a specific archive and press the **OK** key.
6. Press the **OK** or **OVERWRITE ALL** key to overwrite existing files.

OR

7. Press the **DO NOT OVERWRITE** key if you do not want to overwrite already existing files.

OR

8. Press the **SKIP** key if the read-in operation is to be continued with the next file.
9. The **READ IN ARCHIVE** window opens and a progress message box appears for the read-in process.
10. You will then obtain a **READ ERROR LOG FOR ARCHIVE** in which the skipped or overwritten files are listed.
11. Press the **CANCEL** key to cancel the read-in process.

*Note: You may only archive one file at a time.

4.74 Backing Up Tool Data on the 828 Control

Note: Setup data from part programs can only be backed up if they have been saved in the **WORKPIECES** directory.

For part programs, which are located in the **PART PROGRAMS** directory, **SAVE SETUP DATA** is not listed.

1. Select the **PROGRAM MANAGER** operating area.
2. Position the cursor on the program whose tool and zero-point data you wish to back up.
3. Press the **>>** and **ARCHIVE** keys.
4. Press the **SETUP DATA** key.
5. The **BACKUP SETUP DATA** window opens. Select the data you want to back up.
6. Change the specified name of the originally selected program in the **FILE NAME** field, if needed.
7. Press the **OK** key.
8. The setup data will be set up in the same directory in which the selected program is stored as an INI file.

4.8 ADDING A SOFTWARE OPTION ON THE 828 CONTROL

When you receive your machine all license numbers applicable to your order are activated prior to the machine leaving the factory. If you purchase a control option after the machine arrives at your facility you will receive a license number to active on your control. The license will either require you to go online and create a new license key, or this will be already done for you. If you receive a license certificate like pictured in figure one go to step 1, if not and you already have a license (see figure 2) then proceed to step 8 .

1. You need to obtain the hardware serial # (this not the same as the control serial number) follow these steps:

- Press **MENU SELECT**
- Press **SETUP**
- Select **LICENSE** (you may have to press the ^ or > key to see the soft key)
- Record the **CF CARD SERIAL #**

This number can also be found in the CF card located in your electrical cabinet. The number on the card is labeled as CFC SN. **CAUTION:** Machine must be powered down before the card is removed.

2. Once you have obtained your Control Hardware Serial Number you are ready to activate your new license number. Using the internet, log onto: www.Siemens.com/Automation/License
- Click on the link for **DIRECT ACCESS**
 - Enter the **LICENSE # AND DISPATCH NOTE #** from the paperwork into the areas indicated on the web page.

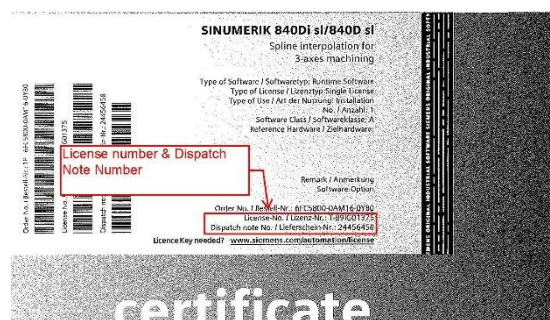

3. Click **NEXT**
4. On the next screen enter your hardware serial number.
5. Next select the control model. Your machine has a 828.
6. The system will now return a software license key
7. Download PDF and save for your records. Also print the PDF so you can refer to it at the machine to type in new license key.
8. Already have printed license see below:



9. Follow step 1 to get to the license screen. Type in (overwriting old license key) current license key and press input. The field is highlighted, make sure to enter correctly.

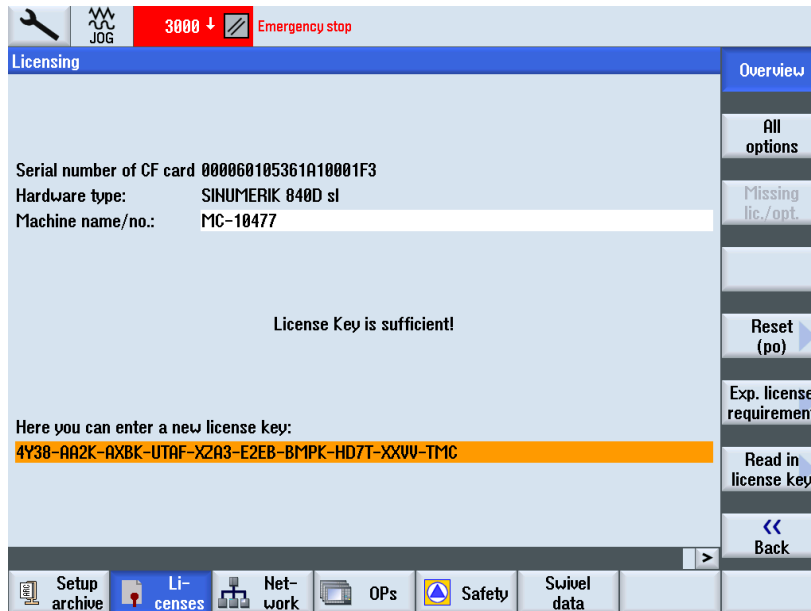

Figure 3

10. Press all options soft key
11. Search for the particular option you want to activate. Set the box with the select key. See figure 4.

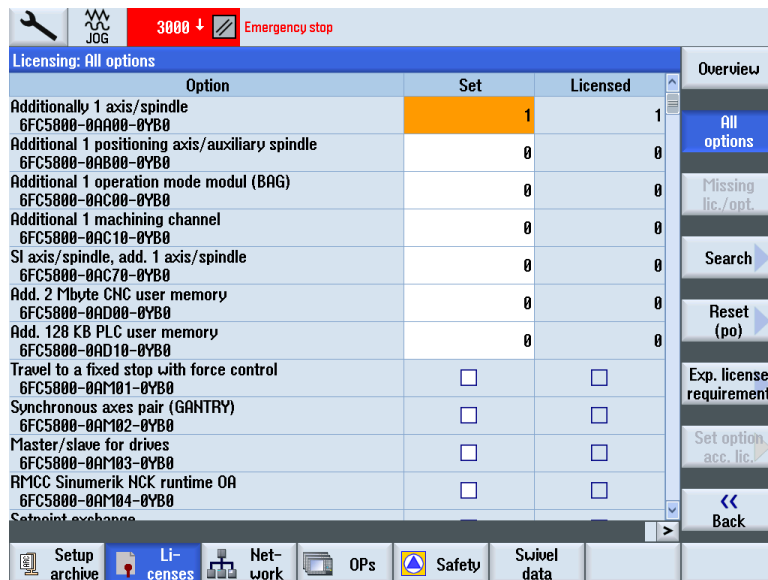

Figure 4

12. Press back soft key and power machine down. When you turn the machine back on the option should be activated.

4.9 SET UP THE NETWORK DRIVE IN AN 828

! NOTE: *It is recommended that this procedure be performed by an experienced network administrator.*

The transfer of programs can be achieved by mapping a soft- key to a networked computer. The soft key will appear in the Program Manager screen of the controller.

The computer connected to the network must be configured with a unique username and password. This information will be required for inputting on the controller. A dedicated shared folder is required on the PC for the storage of files.

- Refer to Section 4.1 for directions to access parameter screens.
1. Press **MENU SELECT**
 2. Select **SETUP**
 3. Select **START-UP**

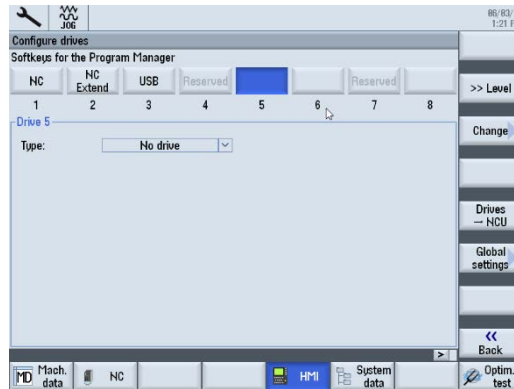

4. Press the **HMI** and **LOG. DRIVE** keys. The **SET UP DRIVES** window opens.
5. Select the open key that you want to configure (**example #5**).
6. To allow entry fields to be edited, press the **CHANGE** key.
7. Select the data for the corresponding drive or enter the necessary data.

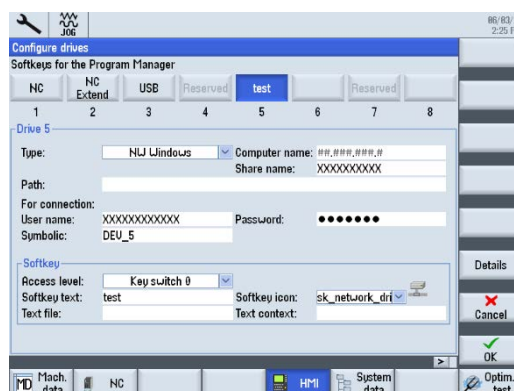
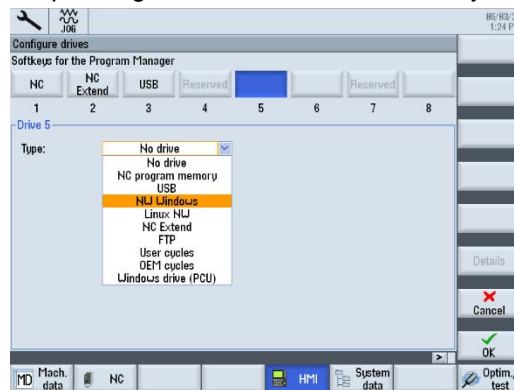

8. Press the **OK** key. The entries are checked. A window with the appropriate message opens if the data is incomplete or incorrect. Acknowledge the message with **OK** key. If you press the **CANCEL** key, then all of the data that has not been activated is rejected.
9. Restart the control in order to activate the configuration and to obtain the keys in the **PROGRAM MANAGER** screen.



5.0 TURRET

5.1 ALIGNING THE TURRET

1. Dial in the riser block perpendicular in relation to X and Z axis



2. Dial in the turret so the face is parallel to X axis. .0002" over 2"
3. The 8 bolts on the turret faceplate loosen it, and it rotates around the ground center puck
4. Dial in the flatness of the tool mount $\pm .0001$ "- loosen 8 center bolts to rotate

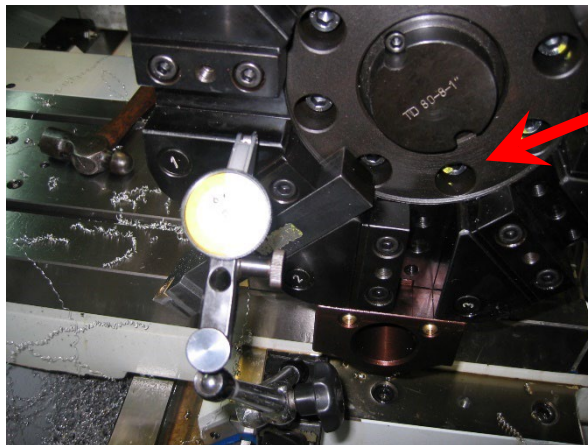

5. Once the turret face plate is parallel to the X axis and the tool mount position is flat to the X axis travel, you can dial in one of the boring holders.

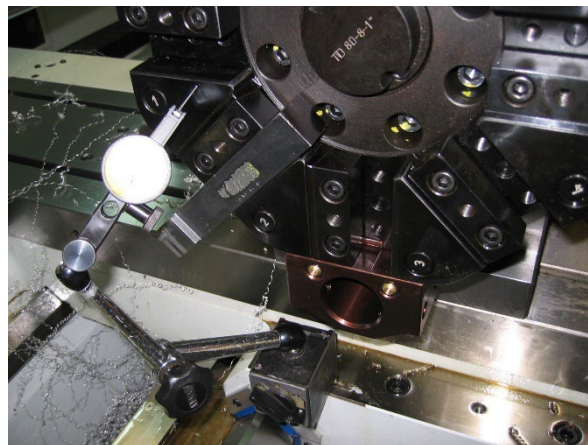

6. Attach indicator to chuck or spindle, place the needle inside the boring holder, and adjust X axis so it is in center of spindle. Set RPM to 10 and use a mirror to check the indicator.
7. Once front to back is even, 0 to 0, any difference top to bottom will have to be compensated by adjusting turret height.
8. If there is any difference in height, shim between the turret and riser block, or grind top of riser.

5.2 DUPLOMATIC ERROR ALARM CODES



DIPLOMATIC

E.M.TMC-230V RELEASE7 10-10

5. DIAGNOSTIC

ALARMS AND WARNINGS

The electronic unit constantly executes self-diagnosis and can signal alarms condition.

An alarm is present if READY is LOW and an ALPOSXX output is different from zero

Turret is in normal operation if READY= ON: in this case the ALPOSxx outputs give the code of the current position.

When an alarm occurs the READY = OFF: in this case AL.POSxx outputs give the alarm code in binary format (ALPOS01= LSB).

Starting from FW 2.0 there is no more separation in group and subgroup.

OUTPUTS						Actual position (READY= ON)	ALARM CODE (READY= OFF)	ALARM DESCRIPTION (READY= OFF)
ALPOS32	ALPOS16	ALPOS08	ALPOS04	ALPOS02	ALPOS01			
0	0	0	0	0	0	Out of position	0.0	No alarm
0	0	0	0	0	1	1	0.1	Non consistent parameters in memory.
0	0	0	0	1	0	2	0.2	Failure in internal power supply.
0	0	0	0	1	1	3	0.3	External 24V DC supply is too low.
0	0	0	1	0	0	4	0.4	Thermal I ² t threshold reached.
0	0	0	1	0	1	5	0.5	Motor overspeed.
0	0	0	1	1	0	6	0.6	Overload: check inertia and friction, check motor and resolver wirings.
0	0	0	1	1	1	7	0.7	Short circuit on power stage: check servomotor wiring or internal damage. (1)
0	0	1	0	0	0	8	0.8	Ground leakage in power stage, check wirings to motor and servomotor. (1)
0	0	1	0	0	1	9	0.9	Internal braking resistor circuit error. (1)
0	0	1	0	1	0	10	1.0	Trouble on power stage control section. (1)
0	0	1	0	1	1	11	1.1	Overvoltage during motor braking. Reduce inertia on the disk. (1)
0	0	1	1	0	0	12	1.2	Undervoltage on threephase
0	0	1	1	0	1	13	1.3	Short circuit on resolver power line (RPOW+, RPOW-) or broken wire on (RSIN+, RSIN-, RCOS+, RCOS-).
0	0	1	1	1	0	14	1.4	Fault on digital outputs: check for external shorts or overloads.
0	0	1	1	1	1	15	1.5	Profile generator fault.
0	1	0	0	0	0	16	1.6	HW ENABLE is not present.
0	1	0	0	0	1	17	1.7	Positioning timeout
0	1	0	0	1	0	18	1.8	Heatsink overtemperature. (1)
0	1	0	0	1	1	19	1.9	Overvoltage on threephase line. Check main supply. (1)
0	1	0	1	0	0	20	2.0	Reached maximum positioning error.
0	1	0	1	0	1	21	2.1	Timeout in cycle execution.
0	1	0	1	1	0	22	2.2	Motor overtemperature. (1)
0	1	0	1	1	1	23	2.3	The signal of Locking switch does not go OFF during unclamping.
0	1	1	0	0	0	24	2.4	The signal of Locking switch has gone ON while turret is unclamped.
0	1	1	0	0	1	N.A.	2.5	The unclamping phase is too slow, check the pressure, and purge the hydraulic circuit.
0	1	1	0	1	0	N.A.	2.6	N.A.
0	1	1	0	1	1	N.A.	2.7	N.A.
0	1	1	1	0	0	N.A.	2.8	The signal of Locking switch has gone OFF while turret is clamped.
0	1	1	1	0	1	N.A.	2.9	Clamping timeout.
0	1	1	1	1	0	N.A.	3.0	N.A.
0	1	1	1	1	1	N.A.	3.1	Need to run the the setup procedure.
1	0	0	0	0	0	N.A.	3.2	Requested tool is not existing
1	0	0	0	0	1	N.A.	3.3	Parity error on tool number request.
1	0	0	0	1	0	N.A.	3.4	PBITXX are changed but PSTART did not came on time.
1	0	0	0	1	1	N.A.	3.5	PLC set EMERGENCY MODE during turret cycle
1	0	0	1	0	0	N.A.	3.6	Trouble during setup procedure execution
1	0	0	1	0	1	N.A.	3.7	Cannot clamp during setup procedure.
1	0	0	1	1	0	N.A.	3.8	Error in D current controller. Check motor and resolver wirings.
1	0	0	1	1	1	N.A.	3.9	Error in Q current controller. Check motor and resolver wirings.
1	0	1	0	0	0	N.A.	4.0	Error in speed controller.
1	0	1	0	0	1	N.A.	4.1	Error in position controller.



1	0	1	0	1	0	N.A.	4.2	N.A.
1	0	1	0	1	1	N.A.	4.3	N.A.
1	0	1	1	0	0	N.A.	4.4	N.A.
1	0	1	1	0	1	N.A.	4.5	N.A.
1	0	1	1	1	0	N.A.	4.6	N.A.
1	0	1	1	1	1	N.A.	4.7	N.A.
1	1	0	0	0	0	N.A.	4.8	N.A.
1	1	0	0	0	1	N.A.	4.9	N.A.
1	1	0	0	1	0	N.A.	5.0	N.A.
1	1	0	0	1	1	N.A.	5.1	N.A.
1	1	0	1	0	0	N.A.	5.2	N.A.
1	1	0	1	0	1	N.A.	5.3	N.A.
1	1	0	1	1	0	N.A.	5.4	N.A.
1	1	0	1	1	1	N.A.	5.5	N.A.
1	1	1	0	0	0	N.A.	5.6	N.A.
1	1	1	0	0	1	N.A.	5.7	N.A.
1	1	1	0	1	0	N.A.	5.8	N.A.
1	1	1	0	1	1	N.A.	5.9	N.A.
1	1	1	1	0	0	N.A.	6.0	N.A.
1	1	1	1	0	1	N.A.	6.1	N.A.
1	1	1	1	1	0	N.A.	6.2	N.A.
1	1	1	1	1	1	N.A.	6.3	N.A.

N/A = No alarm and/or position associated to this code.

(1) = strongly suggested to switch off the threephase supply to TMC controller when power driver alarms are detected.

Display:

A 7-segment display is available.

When the driver is in normal condition all the segments are blinking in sequence.

When the alarm is present, the display will show in sequence, A->(first alarm digit)-> (second alarm digit)

As example, the alarm 2.3 is

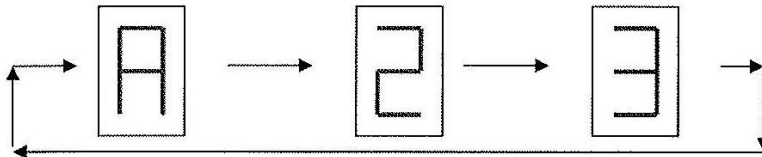

Alarm are stored and can be reset with EMERGENCY/RESET function.

Power off causes the reset of the active alarm.

A PC software is available to improve the stat-up procedure and troubleshooting.

Fault of electronic unit:

After recognizing the fault, the problem can be easily solved.

In case of electronic unit fault, it can be easily replaced.

6.0 - DRAWINGS AND PARTS LIST

6.1 828 CONTROL ELECTRICAL PANEL LAYOUT

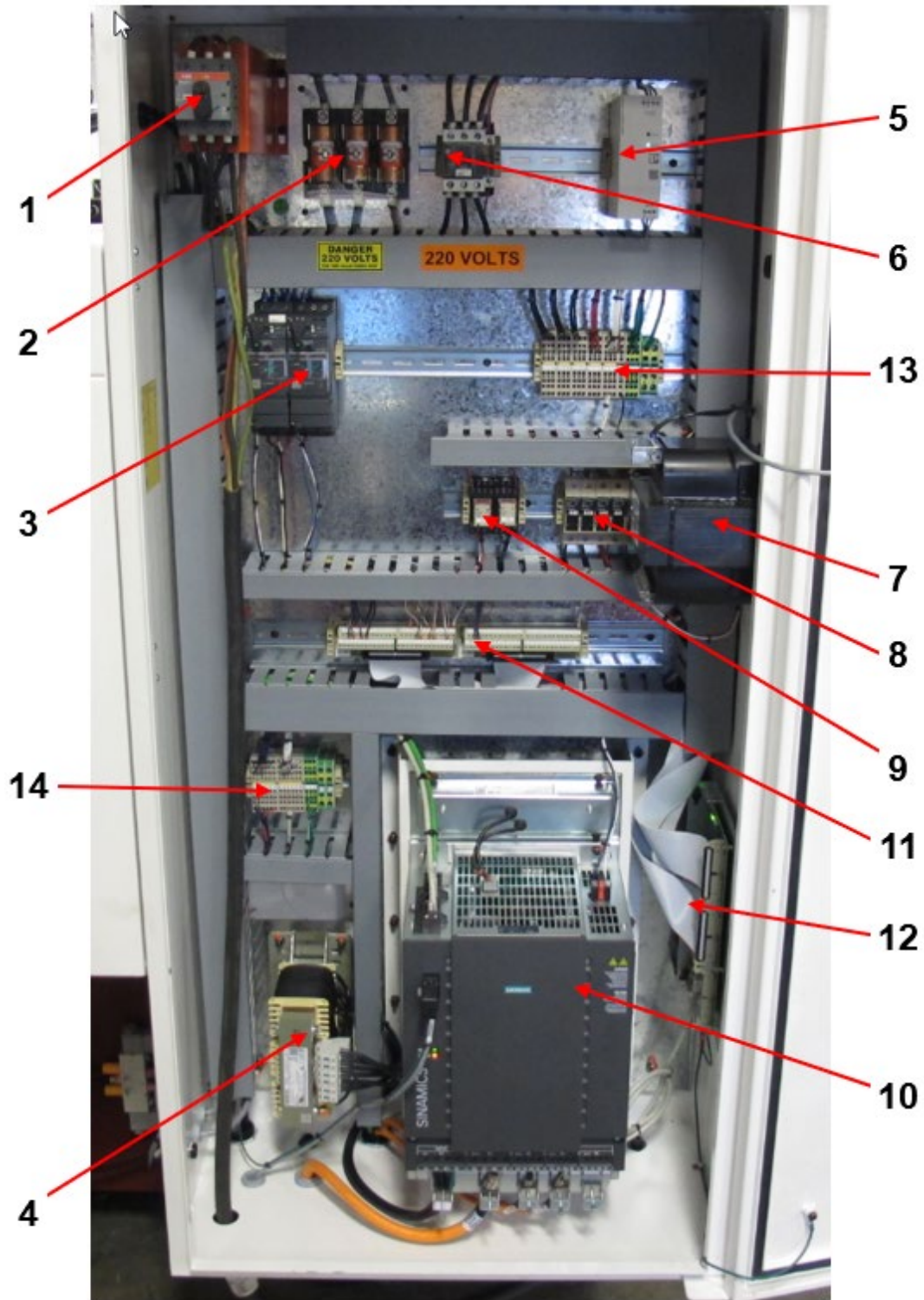

6.1 828 CONTROL ELECTRICAL PANEL – PARTS

REF	PART NO.	DESCRIPTION	PARTS NAME	QTY
1	SWT-5064	Main disconnect		1
2	MSE-1912	Fuse block		1
3		Motor controller overloads		1
4		Line choke		1
5	MSE-2940	24 VDC power supply		1
6	MSE-1410	MC1 magnetic contactor		1
7	MSE-1610	Transformer		1
8		Fuse panel		1
9		Contact relays		1
10		Combi drive		1
11		I/O breakout board		1
12	MSE-1330	I/O card		1
13		Terminal block		1
14		Terminal block		1

6.2 828 FRONT CONSOLE LAYOUT & PARTS



REF	PART NO.	DESCRIPTION	PARTS NAME	QTY
1	MON-4378	Siemens Monitor NCU		1
2	CMB-3202	Siemens Control Panel		1
3	DCL-6052	Apron Panel Decal		1
4	HDL-6094	Handwheel for ET-18/21/25 X & Z		2
5	MSM-8210	Keys (3)		1 set
6	SWT-5052	Joystick Switch		1
7	70131528	Fine / Coarse Toggle Switch		1
8	SwT-6210	e-Stop w/ Contact Block		1

6.3 BASE CASTING DRAWING

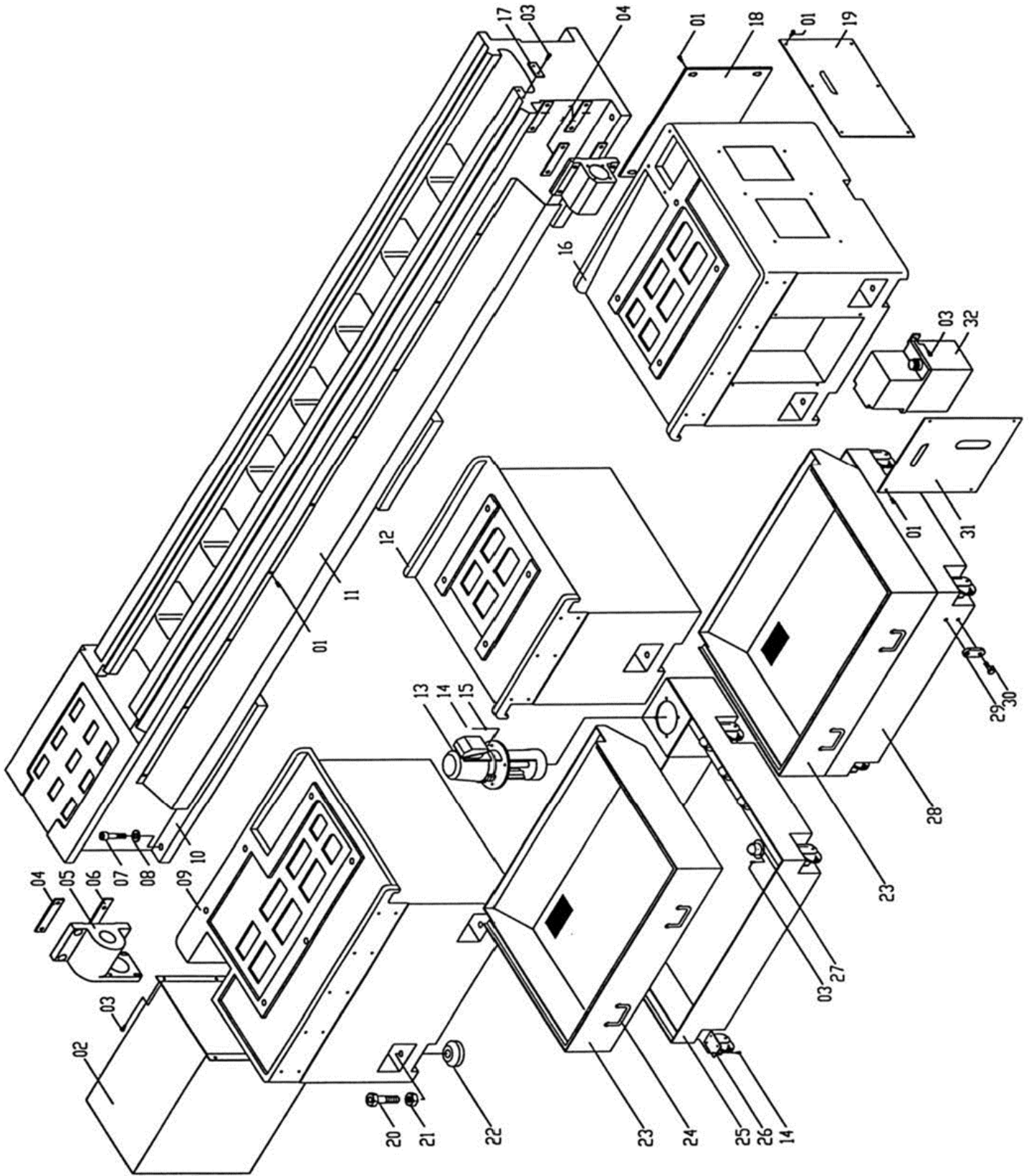

6.3 BASE CASTING PARTS LIST

ET LARGE CAPACITY SERIES - BASE MACHINE DRAWING				
REF NO.	PART NO.	DESCRIPTION	PARTS NAME	Q'TY
1		CAP SCREW	M6xP1.0x12L	
2	26-70005	COVER		
3		SCREW	M6xP1.0x16L	
4	26-20020	SPACER		
5	26-20003	BRACKET		
6	26-20021	SPACER		
7		SCREW	M20xP2.5x70L	
8		SPRING WASHER	M20	
9	26-20002	BASE		
10	26-20001	BED		
11	26-70019	BALL SCREW COVER		
12	26-20023	BASE		
13	BEN-1042	PUMP	1/4HP	
14		SCREW	M8xP1.25x16L	
15		WASHER	M8	
16	26-20004	BASE		
17	18-70025	STOPPER		
18	26-70030	COVER		
19	26-70038	COVER		
20	BEN-2910	FOUNDATION BOLT		
21	BEN-2910	NUT		
22	BEN-2910	FOUNDATION PAD		
23	26-717-1	COOLANT TRAY		
24		HANDLE	4"	
25	26-721-1	COOLANT TRAY		
26		WHEEL	2-1/2"	
27		WHEEL	1"	
28	26-721-2	COOLANT TANK		
29	BEN-2210	OIL SIGHT	3"	
30		SCREW	M10xP1.5x30L	
31	26-70024	COVER		
32	BEN-1015	LUBRICATION SYSTEM		

6.4 ELECTRICAL CABINET DRAWING

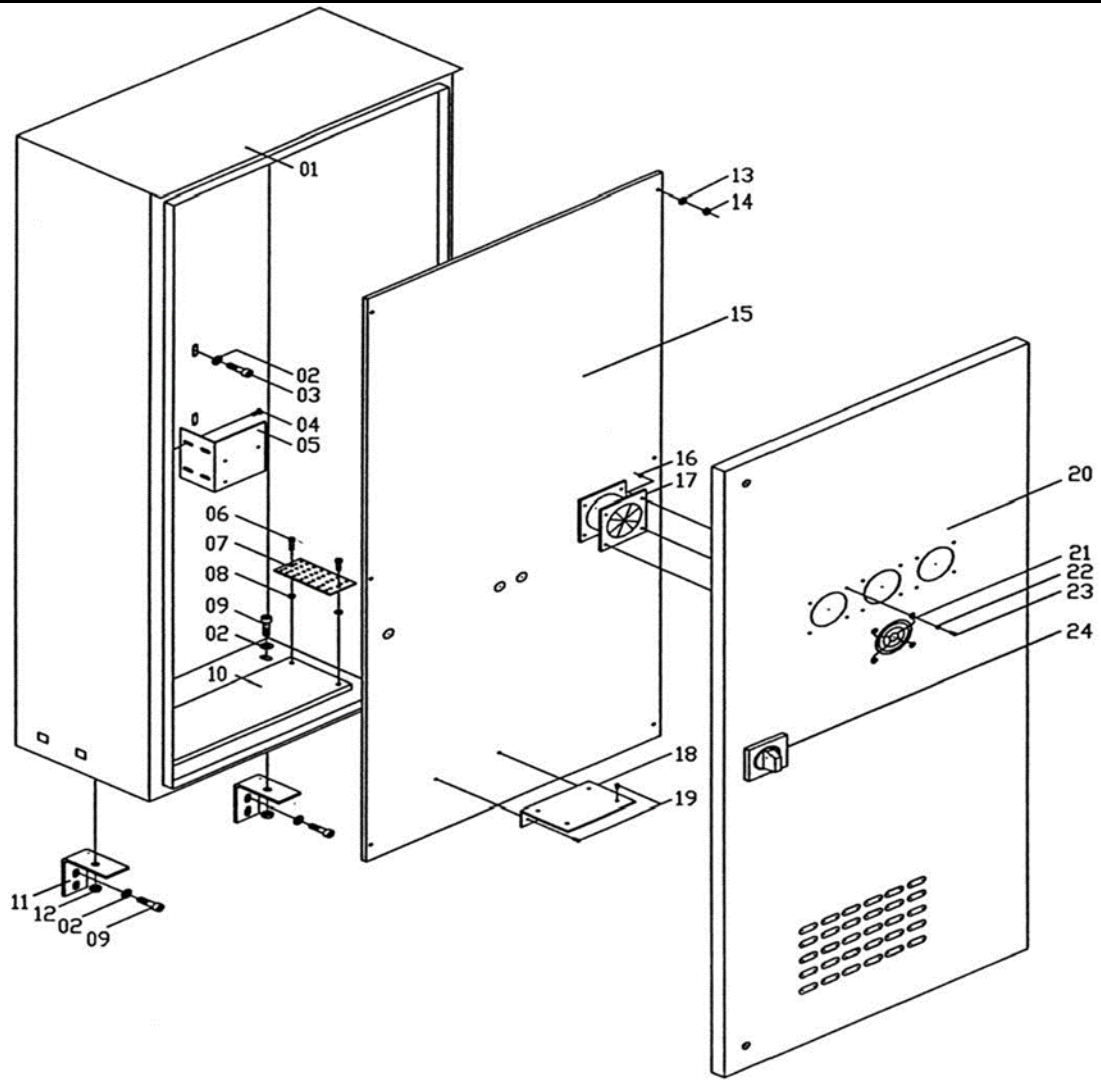

ET LARGE CAPACITY SERIES - ELECTRICAL CABINET PARTS LIST

REF NO.	PART NO.	DESCRIPTION	PARTS NAME	Q'TY
1	26-80001	ELECTRICAL CONTROL BOX		
2		WASHER	M10	
3		SCREW	M10xP1.5x35L	
4		SCREW	M6xP1.0x12L	
5	21-8009A	SUPPORT		
6		SCREW	M6xP1.0x25L	
7	18-80019	COPPER PLATE		
8		NUT	M6	
9		SCREW	M10xP1.5x25L	
10	26-80006	BASE PLATE		
11	18-80010	BRACKET		
12		NUT	M10	
13		WASHER	M8	
14		NUT	M8	
15	26-80003	BASE PLATE		
16		NUT	M4	
17		FAN	5"	
18	18-80028	SUPPORT		
19		CAP SCREW	M4xP0.7x10L	
20	26-80002	DOOR		
21		FAN COVER	5"	
22		WASHER	M4	
23		CAP SCREW	M4xP0.7x16L	
24		MAIN SWITCH	34OH-2S	

6.5 HEADSTOCK DRAWING

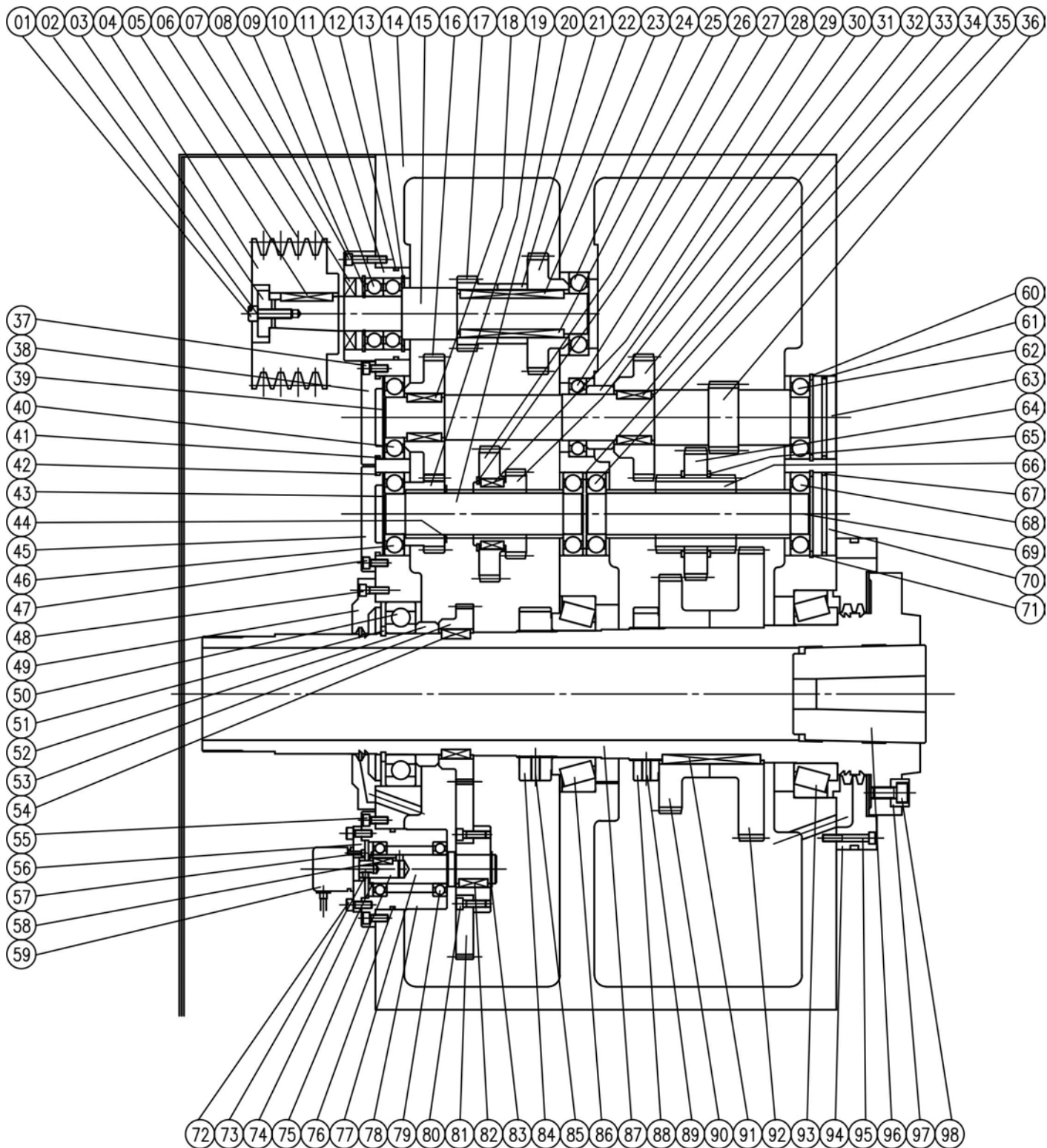

6.5 HEADSTOCK PARTS LIST

ET-30 HEADSTOCK PARTS LIST				
REF NO.	PART NO.	DESCRIPTION	PARTS NAME	QTY.
1		SCREW	M8xP1.25x25L	1
2		SPRING WASHER	M8	1
3	26-10034	WASHER		1
4	26-10033	PULLEY		1
5		KEY	8x8x45L	1
6		BELT	SPA1957	5
7		OIL SEAL	TC-357210	1
8		SCREW	M6xP1.0x30L	5
9		SNAP RING	RTW-72	1
10		BEARING	6207	2
11	26-10003	FLANGE BEARING		1
12		O-RING	G-85	1
13		SNAP RING	RTW-72	1
14	26-10001	HEADSTOCK		1
15	26-10004	SHAFT		1
16	26-10009	GEAR		1
17	26-10005	GEAR		1
18		KEY	8x8x40L	2
19	26-10015	GEAR		1
20	26-10018	SHAFT		1
21	26-10006	COLLAR		1
22	26-10007	GEAR		1
23		KEY	8x8x105L	1
24		BEARING	6208	1
25		KEY	8x8x105L	1
26	26-10016	GEAR		1
27		SNAP RING	STW-65	1
28		BEARING	6009	1
29		KEY	8x8x25L	2
30	26-10010	COLLAR		1
31	26-10017	GEAR		1
32	26-10011	GEAR		1
33		KEY	8x8x40L	2
34	26-10019	COLLAR		1
35		BEARING	6208	2
36	26-10012	GEAR		1
37		SCREW	M6xP1.0x16L	3

38	26-10053	COVER		1
39		WASHER	BWW-6208	1
40		BEARING	6208	1
41		O-RING	G-75	1
42		O-RING	G-75	1
43		WASHER	BWW-6208	1
44		SNAP RING	STW-48	1
45	26-10008	COVER		1
46		BEARING	6208	1
47		SCREW	M6xP1.0x16L	3
48		SCREW	M6xP1.0x16L	6
49	26-10023	COVER		1
50		BEARING	6026, Z	1
51		SNAP RING	STW-130	1
52	26-10028	COLLAR		1
53	26-10029	GEAR		1
54		KEY	10x8x25L	1
55		SCREW	M6xP1.0x16L	4
56	18-10054	BRACKET		1
57		SCREW	M3xP0.5x12L	4
58		KEY	5x5x17L	1
59		ENCODER	LBJ-007-1000	1
60		SNAP RING	RTW-80	1
61		O-RING	G-75	1
62		BEARING	6208	1
63	26-10013	PLUG		1
64	26-10022	GEAR		1
65		SNAP RING	STW-95	2
66	26-10021	GEAR		1
67		O-RING	G-75	1
68		BEARING	6208	1
69	26-10020	SHAFT		1
70	26-10013	PLUG		1
71		SNAP RING	RTW-80	1
72		SCREW	M6xP1.0x16L	3
73		SET SCREW	M5xP0.8x5L	1
74		SNAP RING	STW-25	1
75	18-10055	CLUTCH		1
76		O-RING	G-65	1
77	18-10031	SHAFT		1
78	18-10030	FLANGE BEARING		1
79		BEARING	6005	2

80		SCREW	M6xP1.0x20L	4
81	26-10032	GEAR		1
82		KEY	7x7x25L	1
83		SNAP RING	STW-25	1
84		NUT	YSF-M140x2	1
85		SET SCREW	M10XP1.5X10L	3
86		BEARING	32028	1
87	26-10024A	SPINDLE		1
88		NUT	YSR-M145x2	1
89		SET SCREW	M10XP1.5X10L	3
90	26-10025	GEAR		1
91		KEY	16x10x100L	1
92	26-10026	GEAR		1
93		BEARING	32030	1
94	26-10027A	COVER		1
95		SCREW	M6xP1.0x40L	5
96	26-10014	SLEEVE		1
97	26-10048A	DRIVE KEY		1
98		SCREW	M10xP1.5x25L	1

6.6 HEADSTOCK WITH 6" BORE - DRAWING & PARTS LIST

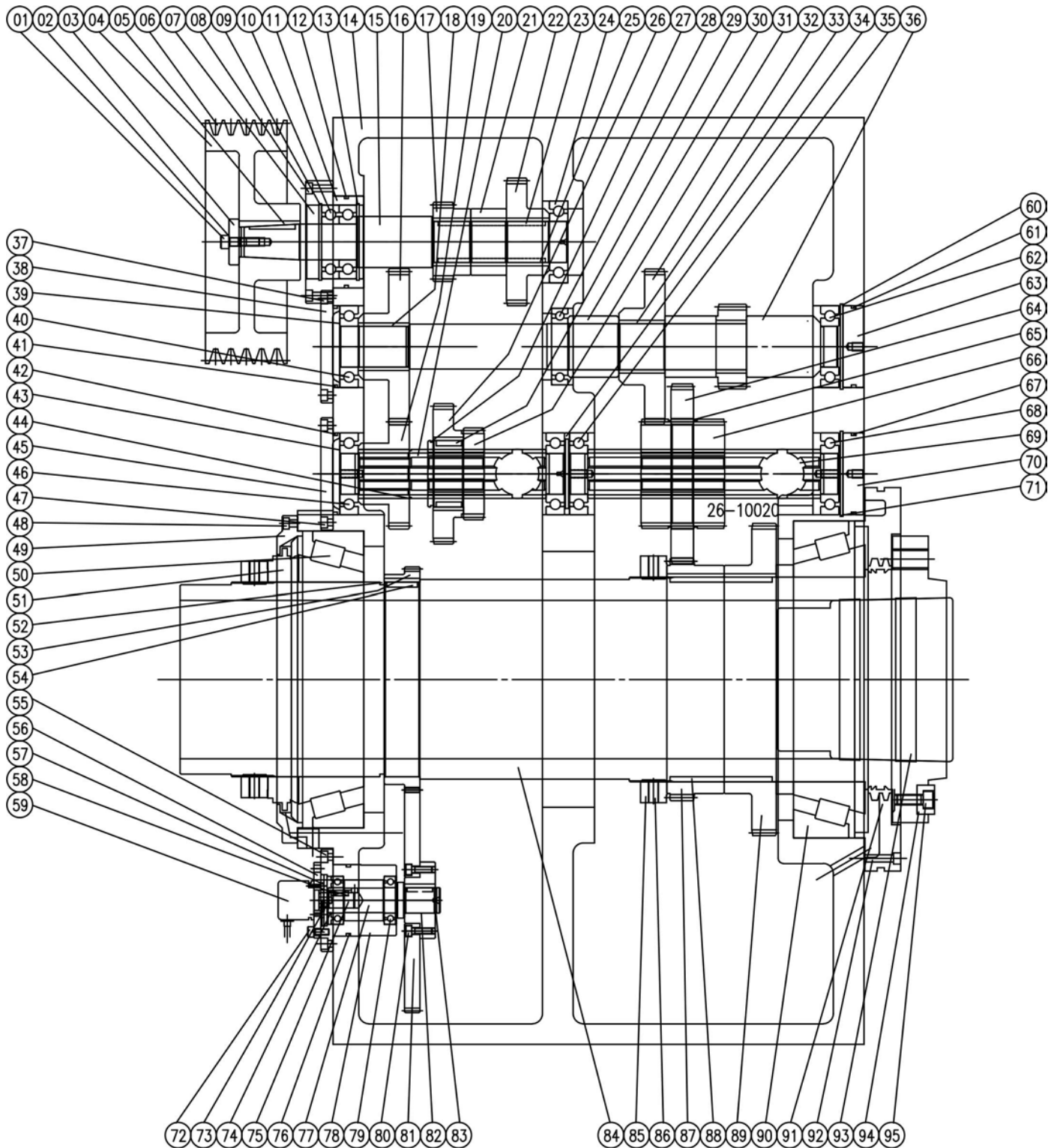

6.6 HEADSTOCK WITH 6" BORE - DRAWING & PARTS LIST

ET-30 6-INCH PARTS LIST				
REF NO.	PART NO.	DESCRIPTION	PARTS NAME	QTY.
01		SCREW	M8xP1.25x25L	1
02		SPRING WASHER	M8	1
03	26-10034	WASHER		1
04	26-10033B	PULLEY		1
05		KEY	8x8x45L	1
06		BELT	SPA	5
07		OIL SEAL	TC-357210	1
08		SCREW	M6xP1.0x30L	5
09		SNAP RING	RTW-72	1
10		BEARING	6207	2
11	26-10003	FLANGE BEARING		1
12		O-RING	G-85	1
13		SNAP RING	RTW-72	1
14	26-10001B	HEADSTOCK		1
15	26-10004	SHAFT		1
16	26-10009B	GEAR		1
17	26-10005	GEAR		1
18		KEY	8x8x40L	2
19	26-10015B	GEAR		1
20	26-10018B	SHAFT		1
21	26-10006	COLLAR		1
22	26-10007	GEAR		1
23		KEY	8x8x105L	1
24		BEARING	6208	1
25		KEY	8x8x105L	1
26	26-10016	GEAR		1
27		SNAP RING	STW-65	1
28		BEARING	6009	1
29		KEY	8x8x25L	2
30	26-10010	COLLAR		1
31	26-10017	GEAR		1
32	26-10011B	GEAR		1
33		KEY	8x8x40L	2
34	26-10019	COLLAR		1
35		BEARING	6208	2
36	26-10012B	GEAR		1
37		SCREW	M6xP1.0x16L	3
38	26-10053	COVER		1
39		WASHER	BWW-6208	1
40		BEARING	6208	1
41		O-RING	G-75	1
42		O-RING	G-75	1
43		WASHER	BWW-6208	1

44		SNAP RING	STW-48	1
45	26-10008B	COVER		1
46		BEARING	6208	1
47		SCREW	M6xP1.0x16L	3
48		SCREW	M6xP1.0x16L	6
49	26-10023B	COVER		1
50		BEARING	32038	1
51	26-10077B	WASHER		1
52	26-10028	SNAP RING	STW-190	1
53	26-10029B	GEAR		1
54		KEY	10x8x25L	1
55		SCREW	M6xP1.0x16L	4
56	18-10054	BRACKET		1
57		SCREW	M3xP0.5x12L	4
58		KEY	5x5x17L	1
59		ENCODER	LBJ-007-1000	1
60		SNAP RING	RTW-80	1
61		O-RING	G-75	1
62		BEARING	6208	1
63	26-10013	PLUG		1
64	26-10022B	GEAR		1
65		SNAP RING	STW-95	2
66	26-10021B	GEAR		1
67		O-RING	G-75	1
68		BEARING	6208	1
69	26-10020	SHAFT		1
70	26-10013	PLUG		1
71		SNAP RING	RTW-80	1
72		SCREW	M6xP1.0x16L	3
73		SET SCREW	M5xP0.8x5L	1
74		SNAP RING	STW-25	1
75	18-10055	CLUTCH		1
76		O-RING	G-65	1
77	18-10031	SHAFT		1
78	18-10030	FLANGE BEARING		1
79		BEARING	6005	2
80		SCREW	M6xP1.0x20L	4
81	26-10032B	GEAR		1
82		KEY	7x7x25L	1
83		SNAP RING	STW-25	1
84	26-10024B1	SPINDLE		1
85		NUT	YSR-M200x3	1
86		SET SCREW	M10XP1.5X10L	3
87	26-10025B1	GEAR		1
88		KEY	16x10x100L	1
89	26-10026B1	GEAR		1
90		BEARING	32040	1
91	26-10027B	COVER		1

92		SCREW	M6xP1.0x40L	5
93	26-10014B	SLEEVE		1
94	26-10048A	DRIVE KEY		1
95		SCREW	M10xP1.5x25L	1

6.7 HEADSTOCK LUBRICATION SYSTEM DRAWING & PARTS LIST

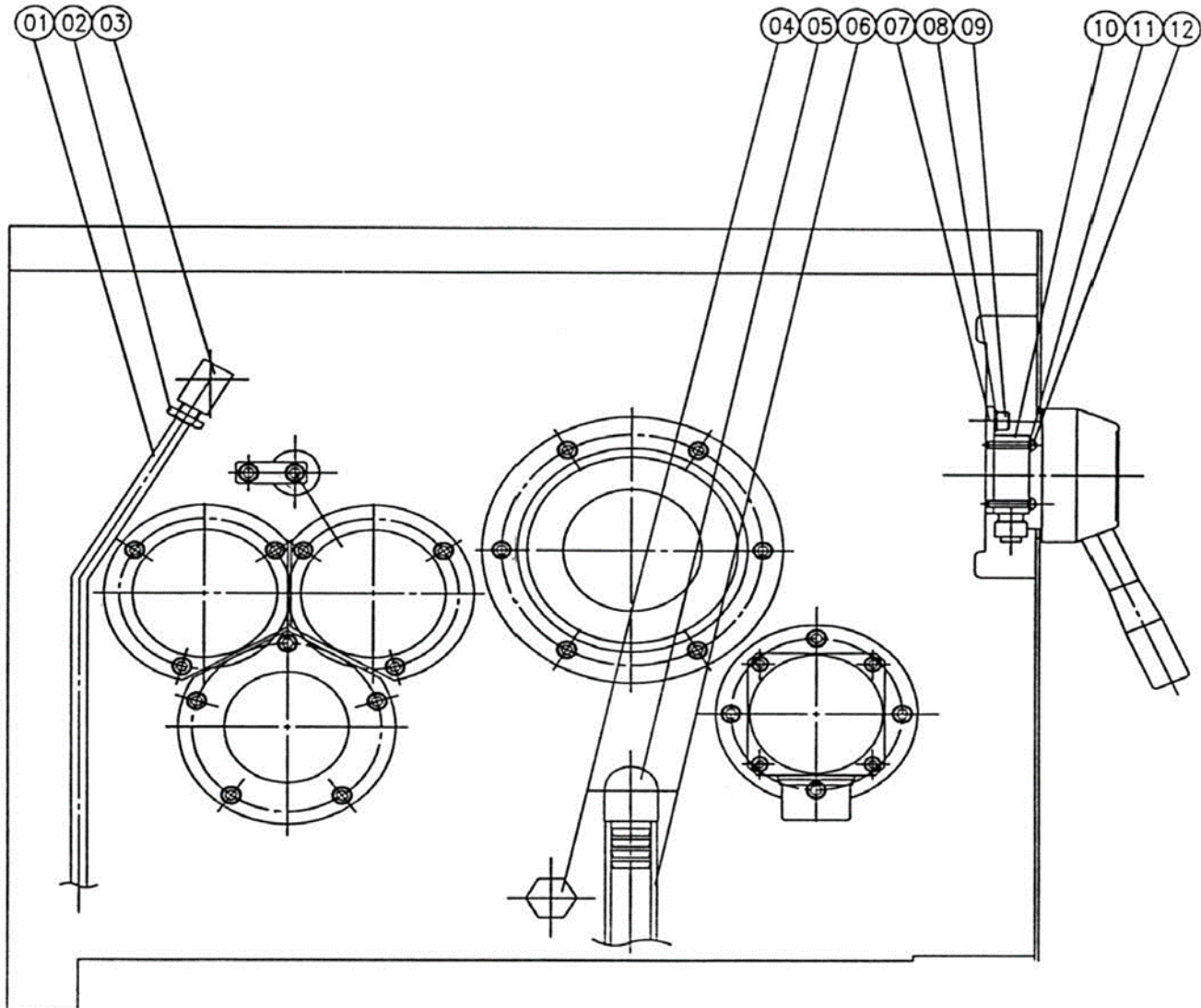

ET LC SERIES - HEAD LUBE PARTS LIST

REF NO.	PART NO.	DESCRIPTION	PARTS NAME	Q'TY
1		PIPE	6x1200L	
2		COMPRESSION BUSHING	PA-6	
3		ELBOW CONNECTOR	PH-602	
4		PLUG	PT1/2"	
5		ELBOW ADAPTER	PT3/4"xPE3/4"	
6		REINFORCED PLASTIC HOSE	3/4"x900L	
7	18-80024	LIMIT SWITCH PLATE		
8		SPRING WASHER	M6	
9		SCREW	M6xP1.0x16L	
10		LIMIT SWITCH		
11		SPRING WASHER	M4	
12		CAP SCREW	M4xP0.7x22L	

6.8 X AXIS ASSEMBLY DRAWING & PARTS LIST

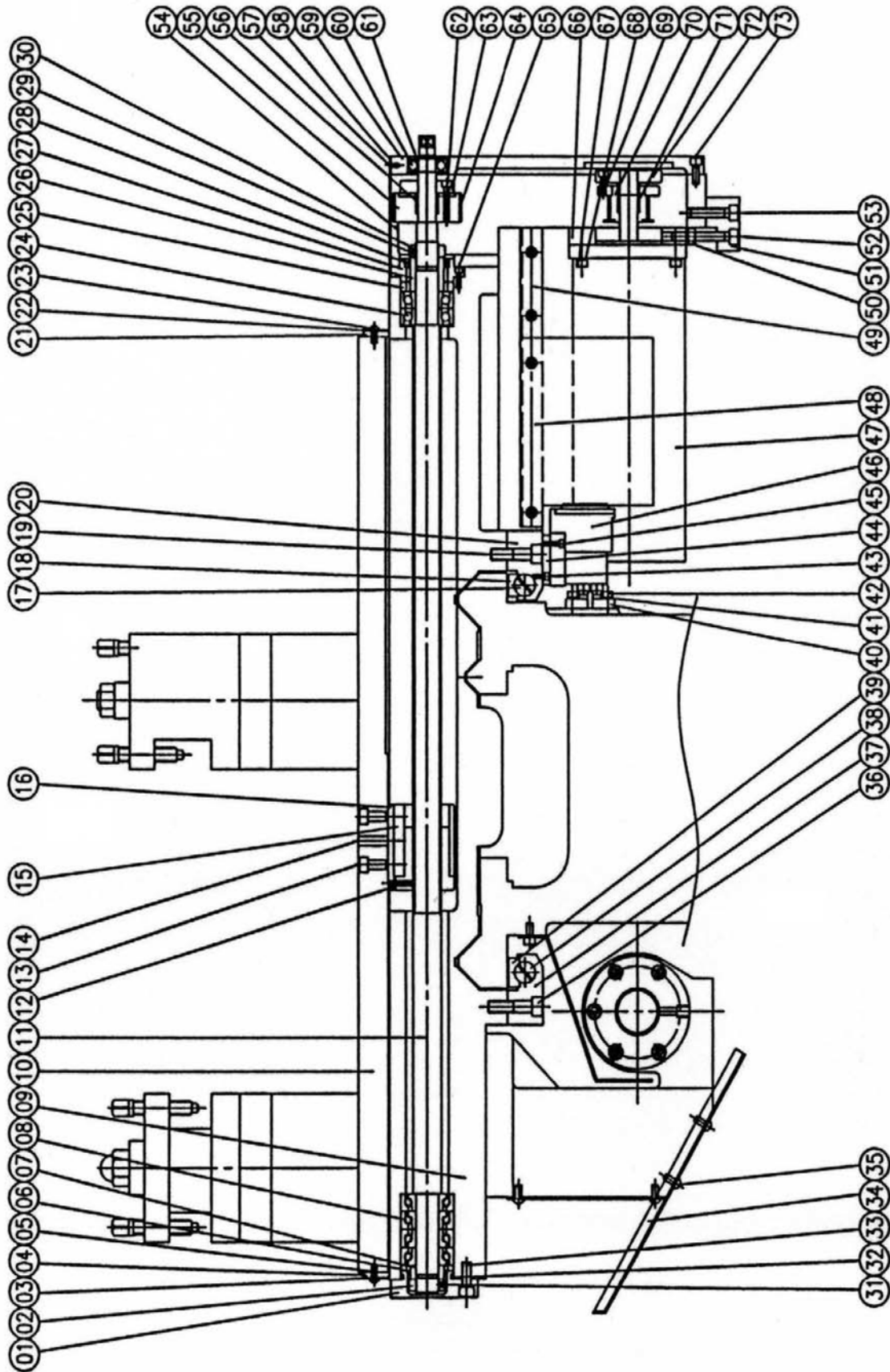

ET LC SERIES - X AXIS PARTS LIST

REF NO.	PART NO.	DESCRIPTION	PARTS NAME	Q'TY
1	26-40015	COVER		
2		NUT	YSR-M25x1.5	
3	26-40025	WIPER COVER		
4	BEN 2936	WIPER X AXIS		
5		CAP SCREW	M5xP0.8x12L	
6	26-40016	COLLAR		
7	26-40032	COLLAR		
8		BEARING	25TAC62B	
9	26-40001	SADDLE		
10	26-40002	CROSS SLIDE		
11	26-40014	BALL SCREW		
12		O-RING	P-5	
13		SCREW	M8xP1.25x50L	
14		TAPER PIN	#6x60L	
15	26-40017	NUT BASE		
16	26-40018	SPACER		
17	18-40024	SCREW		
18	26-40021	GIB		
19		SCREW	M12xP1.75x45L	
20	26-40019	STRIP		
21	26-40046	WIPER		
22	26-40045	WIPER COVER		
23		CAP SCREW	M5xP0.8x12L	
24		BEARING		7205
25	26-40005	COLLAR		
26	26-40009	COLLAR		
27	26-40006	FLANGE BEARING		
28		OIL SEAL	TC-354508	
29		SET SCREW	M6xP1.0x6L	
30		NUT	YSR-M25x1.5	
31		SET SCREW	M6xP1.0x6L	
32		O-RING	G-55	
33		SCREW	M8xP1.25x20L	
34	26-70022	PLATE		
35		CAP SCREW	M6xP1.0x12L	
36		SCREW	M12xP1.75x45L	
37	26-40020	STRIP		
38	18-40024	SCREW		
39	26-40021	GIB		
40	18-40033	DOG		
41		SPRING WASHER	M5	
42		SCREW	M5xP0.8x12L	
43		SCREW	M6xP1.0x16L	
44	26-80026	SPACER		
45		SCREW	M6xP1.0x22L	
46	BEN-2362	LIMIT SWITCH	GSBFD 12-502	
47		SERVO MOTOR	HJ-130B8-64	
48	18-80015	COVER		
49	18-80014	COVER		
50		NUT	M8	
51	18-4008D	BLOCK		
52		SCREW	M8xP1.25x55L	
53		SCREW	M8xP1.25x40L	
54	26-40003	BRACKET		
55	26-40011	PULLEY		
56		CLAMP ELEMENT	SCE300-20x25	
57		SCREW	M5xP0.8x12L	
58	26-70041	COVER		
59	26-40004	COVER		
60		BEARING	6202.ZZ	
61		SNAP RING	STW-15	
62		SCREW	M5xP0.8x20L	
63	26-40013	PRESSURE FLANGE		
64		BELT	HTD-560-5M-20	
65		SCREW	M6xP 1.0x16L	
66	26-40007	MOTOR BASE		
67		SCREW	M8xP 1.25x20L	
68		SPRING WASHER	M8	
69		SCREW	M5xP0.8x20L	
70	26-40010	PULLEY		
71		CLAMP ELEMENT	SCE300-19x24	
72	26-40012	PRESSURE FLANGE		
73		SCREW	M6xP 1.0x20L	

6.9 Z AXIS ASSEMBLY DRAWING & PARTS LIST

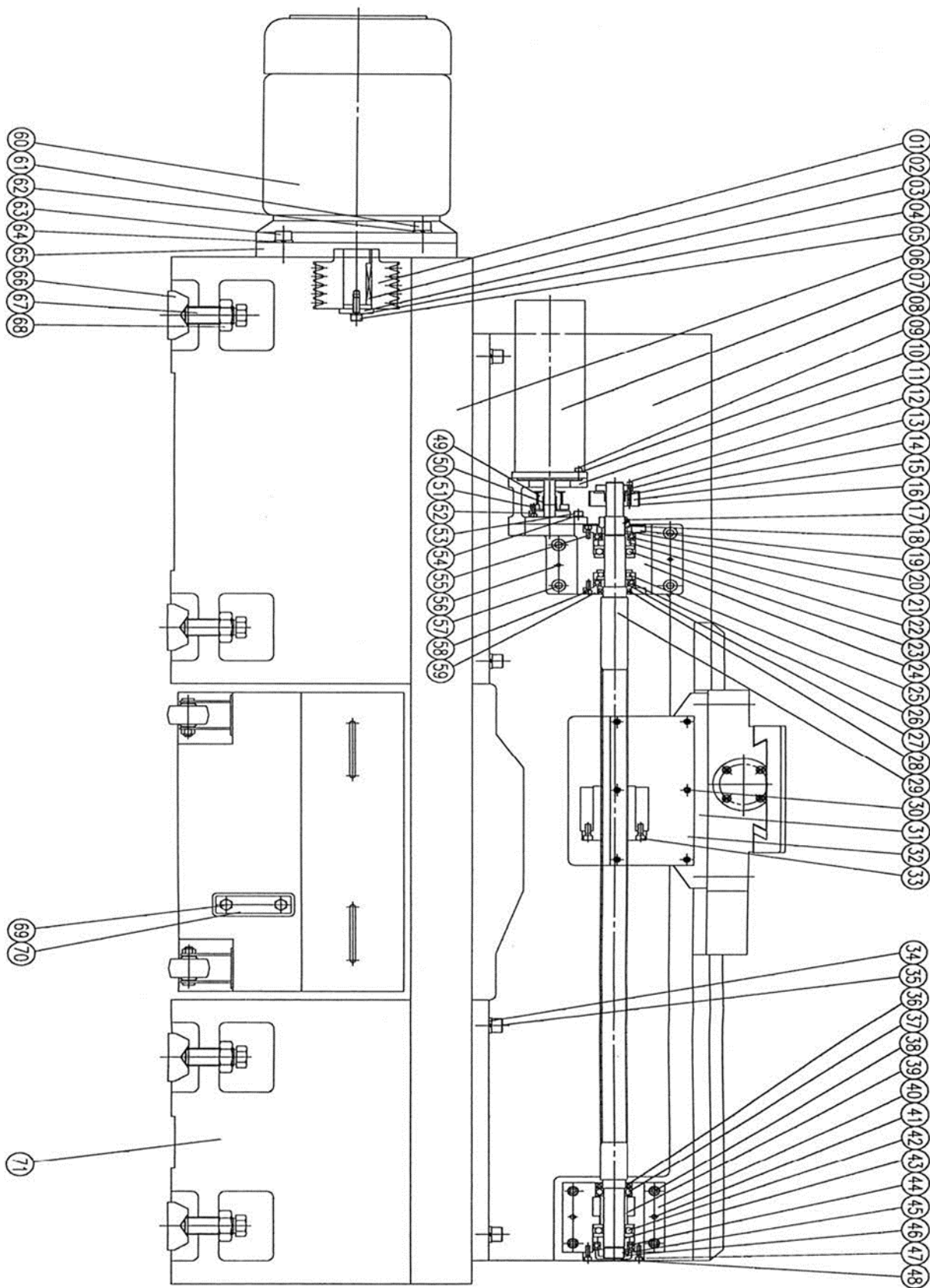

ET LARGE CAPACITY SERIES - Z AXIS PARTS LIST

REF				
NO.	PART NO.	DESCRIPTION	PARTS NAME	Q'TY
1	26-20016	PULLEY		
2		KEY	12x8x80L	
3	18-20015	WASHER		
4		SPRING WASHER	M10	
5		SCREW	M10xP1.5x30L	
6	26-20002	BASE		
7	MTR-3022	SERVO MOTOR		
8	26-20001	BED		
9		SCREW	M8xP1.25x25L	
10		SPRING WASHER	M8	
11	26-20005	MOTOR BASE		
12		SCREW	M5xP0.8x20L	
13	21-20022	PRESSURE FLANGE		
14		CLAMP ELEMENT	SCE300-25x30	
15	21-20004	PULLEY		
16		BELT		
17		SET SCREW	M8xP1.25x8L	
18		NUT	YSF-M40x1.5	
19	26-20007	COVER		
20	26-20026	COLLAR		
21	POL-1650	BEARING		
22	26-20006	BUSH		
23		BEARING		
24	26-20003	BRACKET		
25		BEARING		
26		BEARING		
27	26-20008	BUSH		
28		OIL SEAL	TC-506809	
29	26-20009	BALL SCREW		
30		CAP SCREW	M6xP1.0x12L	
31	26-20010	APRON		
32	26-70023	COVER		
33		SCREW	M10xP1.5x25L	
34		SPRING WASHER	M20	
35		SCREW	M20xP2.5x70L	
36		OIL SEAL	TC-506809	
37		BEARING	6008,Z	
38		SCREW	M12xP1.75x50L	
39	26-20012	BUSH		
40	26-20011	BRACKET		
41		TAPER PIN	#7x50L	
42		BEARING		51309
43	26-20006	BUSH		
44	POL-1650	BEARING		
45		SET SCREW	M8xP1.25x8L	
46		NUT	YSR-M40x1.5	
47		SCREW	M6xP1.0x30L	
48	26-20014	COVER		
49	26-20024	PULLEY		
50		CLAMP ELEMENT	SCE300-22x26	
51		SCREW	M5xP0.8x20L	
52	26-20025	PRESSURE FLANGE		
53		SCREW	M8xP1.25x30L	
54		SPRING WASHER	M8	
55		SCREW	M6xP1.0x16L	
56		TAPER PIN	#7x50L	
57		SCREW	M12xP1.75x50L	
58		SCREW	M6xP1.0x16L	
59	26-20013	COVER		
60		MOTOR	AEVF-15HP	
61		SCREW	M16xP2.0x45L	
62		SPRING WASHER	M16	
63		SCREW	M16xP2.0x55L	
64		SPRING WASHER	M16	
65	26-20017	MOTOR BASE		
66	18-20019	FOUNDATION PAD		
67	18-20018	FOUNDATION BOLT		
68		NUT	M30	
69		SCREW	M10xP1.5x30L	
70		OIL SIGHT	LS-3"	
71	26-20004	BASE		

6.10 SADDLE DRAWING #1 & PARTS LIST

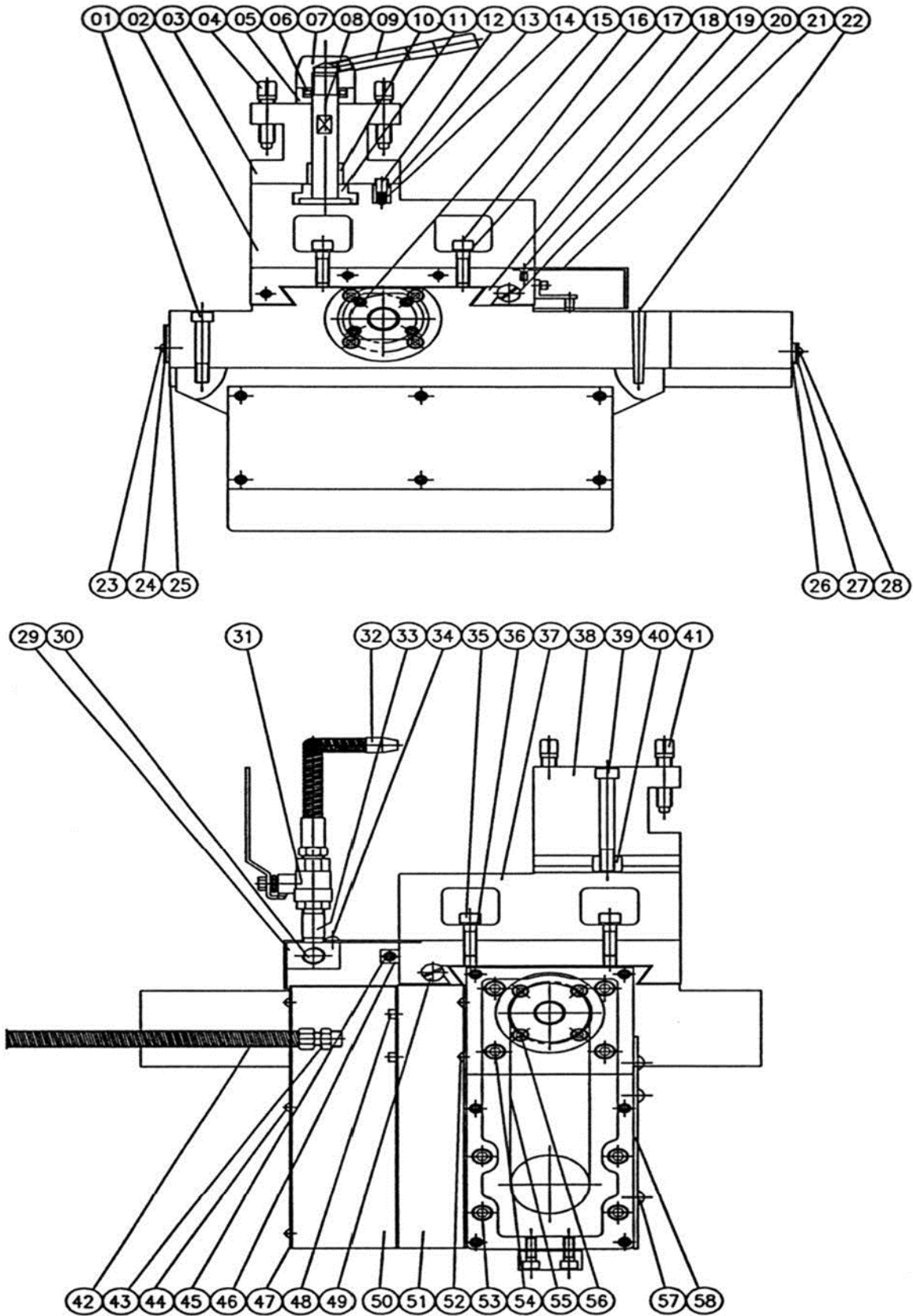

6.10 SADDLE DRAWING #1 & PARTS LIST

ET LC SERIES - SADDLE FRONT & BACK VIEW				
REF NO.	PART NO.	DESCRIPTION	PARTS NAME	Q'TY
1		SCREW	M12xP1.75x110	
2	26-40034	BLOCK		
3	26-40036	TOOL POST		
4	26-40037	SCREW		
5	26-40039	WASHER		
6		BEARING		
7	26-40062	TURRET CAP		
8	26-40041	SHAFT		
9	26-40063	HANDLE		
10	26-40038	COLLAR		
11	26-40042	LOCKING BLOCK		
12	26-40043	STOPPER		
13	26-40044	SLEEVE		
14		SPRING	3/8"x1/2"L	
15		SCREW	M6xP1.0x16L	
16		SCREW	M10xP1.5x45L	
17		SPRING WASHER	M10	
18	26-40023	GIB		
19		SCREW	M6xP1.0x12L	
20	18-40024	SCREW		
21	26-70039	COVER		
22		TAPER PIN	#7x120L	
23		CAP SCREW	M5xP0.8x12L	
24	26-40028	WIPER COVER		
25	BEN-2938	Z AXIS WIPER	SET	
26	BEN-2938	Z AXIS WIPER	SET	
27	18-40028	WIPER COVER		
28		CAP SCREW	M5xP0.8x12L	
29	26-40049	BLOCK		
30		TUBE	12x780L	
31		VALVE GATE	3/8"	
32		SPRAYING PIPE	3/8"x30"L	
33		TUBE	3/8"x120L	
34		CAP SCREW	M6xP1.0x12L	
35		SCREW	M10xP1.5x45L	
36		SPRING WASHER	M10	
37	26-40035	BLOCK		
38	26-40048	REAR TOOL POST		
39		SCREW	M10xP1.5x130L	
40	18-40047	LOCKING BLOCK		
41	26-40037	SCREW		
42		PIPE	CT702-400"L	
43		NIPPLE	3/8"PTx3/8"PS	
44		CAP SCREW	M6xP1.0x12L	
45		FLEXBLE HOUSE	6x1600L	
46		QUARTER JOINT	PH-4	
47	26-80021	COVER		
48		SCREW	M6xP1.0x12L	
49	18-40024	SCREW		
50	26-80020	BOX		
51	26-80035	BRACKET		
52		CAP SCREW	M6xP1.0x12L	
53		SCREW	M10xP1.5x45L	
54		SCREW	M10xP1.5x30L	
55		BELT	HTD-560-5M-20	
56		SCREW	M6xP1.0x16L	
57		CAP SCREW	M6xP1.0x12L	
58	26-80018	PLATE	M10xP1.5x30L	

6.11 SADDLE DRAWING #2 & PARTS LIST

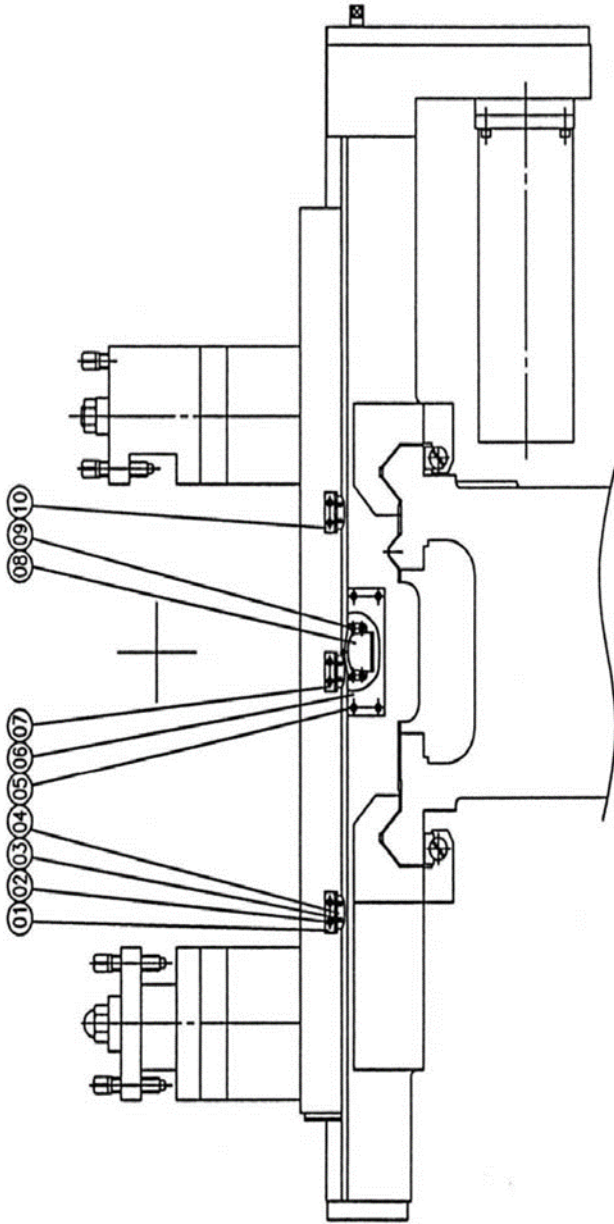

SADDLE 2 PARTS LIST

ET LC SERIES - SADDLE SIDE VIEW PARTS LIST

REF NO.	PART NO.	DESCRIPTION	PARTS NAME	Q'TY
1	26-80016	BRACKET		
2		SCREW	M6xP1.0x16L	
3		SCREW	M5xP0.8x12L	
4	26-40033	DOG		
5		SCREW	M6xP1.0x12L	
6	26-80012	PLATE		
7	26-80017	BRACKET		
8	BEN-2360	LIMIT SWITCH		
9		SCREW	M5xP0.8x18L	
10	26-80016	BRACKET		

6.12 SHEET METAL ASSEMBLY DRAWING & PARTS LIST

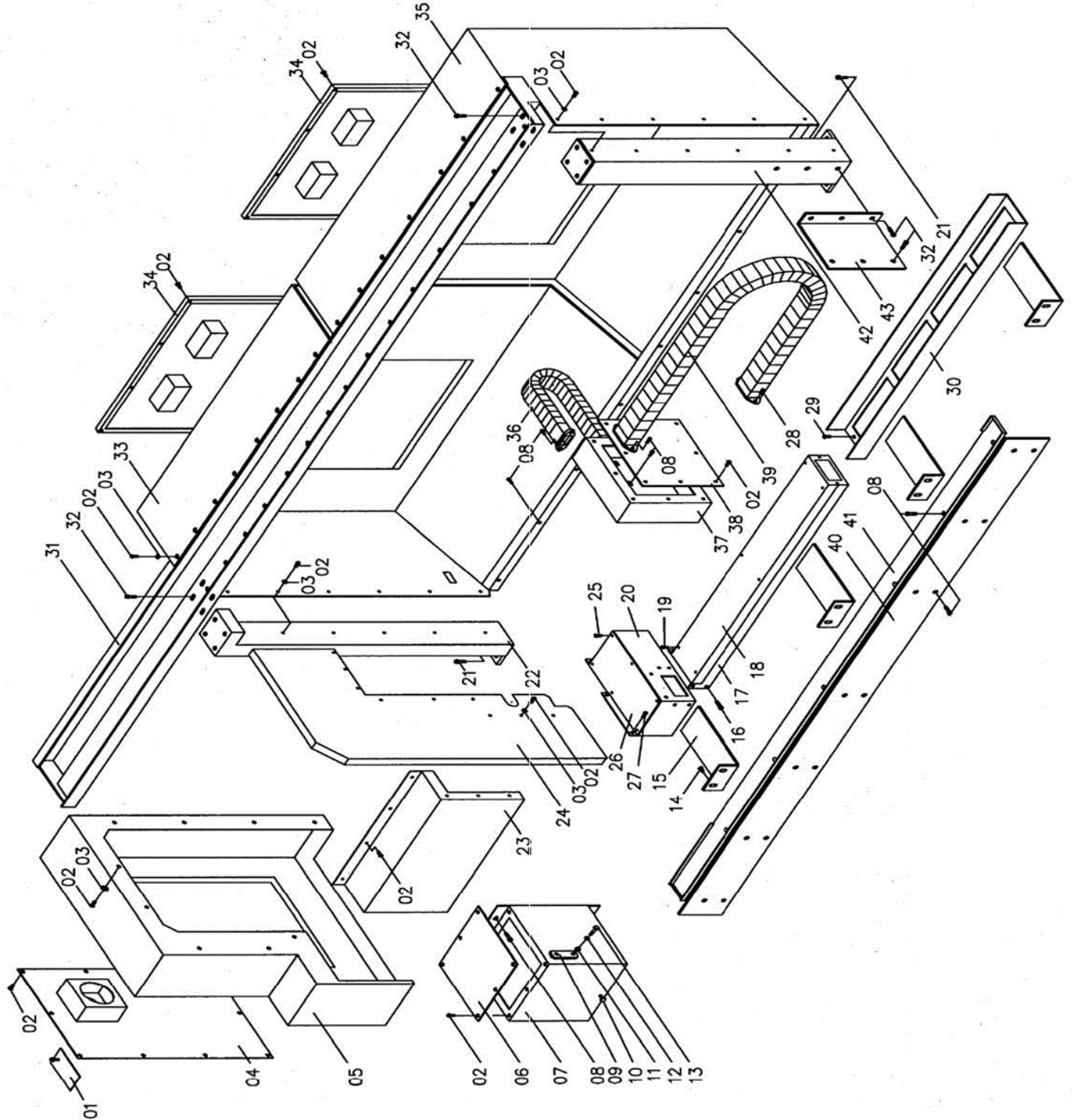

6.12 SHEET METAL ASSEMBLY DRAWING & PARTS LIST

PARTS LIST				
REF NO.	PART NO.	DESCRIPTION	PARTS NAME	Q'TY
0 1	26-70032	FILTER		1
0 2		CAP SCREW	M6xP1.0x12L	8 2
0 3		WASHER	M6	5 3
0 4	26-70001	COVER		1
0 5	26-70002	END COVER		1
0 6	18-70029	OIL TANK COVER		1
0 7	26-70028	OIL TANK		1
0 8		SCREW	M6xP1.0x16L	3 9
0 9		OIL SIGHT	LS-3"	1
1 0		PLUG	PT1/2"	1
1 1		NUT	M10	2
1 2		GASTET	M10	2
1 3		SCREW	M10xP1.5x30L	2
1 4		SCREW	M8xP1.25x25L	10
1 5	26-80061	BRACKET		5
1 6		SCREW	M6xP1.0x8L	6
1 7	26-80066A	TRUNKING		1
1 8	26-80066B	TRUNK COVER		1
1 9		SCREW	M6xP1.0x8L	6
2 0	26-80063	TRUNKING		1
2 1		SCREW	M8xP1.25x20L	6
2 2	26-70042	BRACKET		1
2 3	26-70013	COVER		1
2 4	26-70014	COVER		1
2 5		SCREW	M6xP1.0x8L	6
2 6	26-80064	TRUNK COVER		1

6.12 SHEET METAL ASSEMBLY DRAWING & PARTS LIST

P A R T S L I S T				
REF NO.	PART NO.	DESCRIPTION	PARTS NAME	Q'TY
2 7		SCREW	M6xP1.0x8L	2
2 8		SCREW	M6xP1.0x16L	2
2 9		SCREW	M8xP1.25x16L	2
3 0	26-80060	BRACKET		1
3 1	26-70044	BRACKET		1
3 2		SCREW	M8xP1.25x16L	1 4
3 3	26-703-1	SPLASH GUARD		1
3 4	18-70004	REAR COVER		2
3 5	26-703-2	SPLASH GUARD		1
3 6		FLEXIBLE CARRIER	BB100700	1
3 7	26-80020	BOX		1
3 8	26-80021	COVER		1
3 9		FLEXIBLE CARRIER	BB2002200	1
4 0	26-70016	GUIDE RAIL		1
4 1	26-70015	COVER		1
4 2	26-70043	BRACKET		1
4 3	26-70026	BRACKET		1

6.13 DOOR ASSEMBLY DRAWING & PARTS LIST

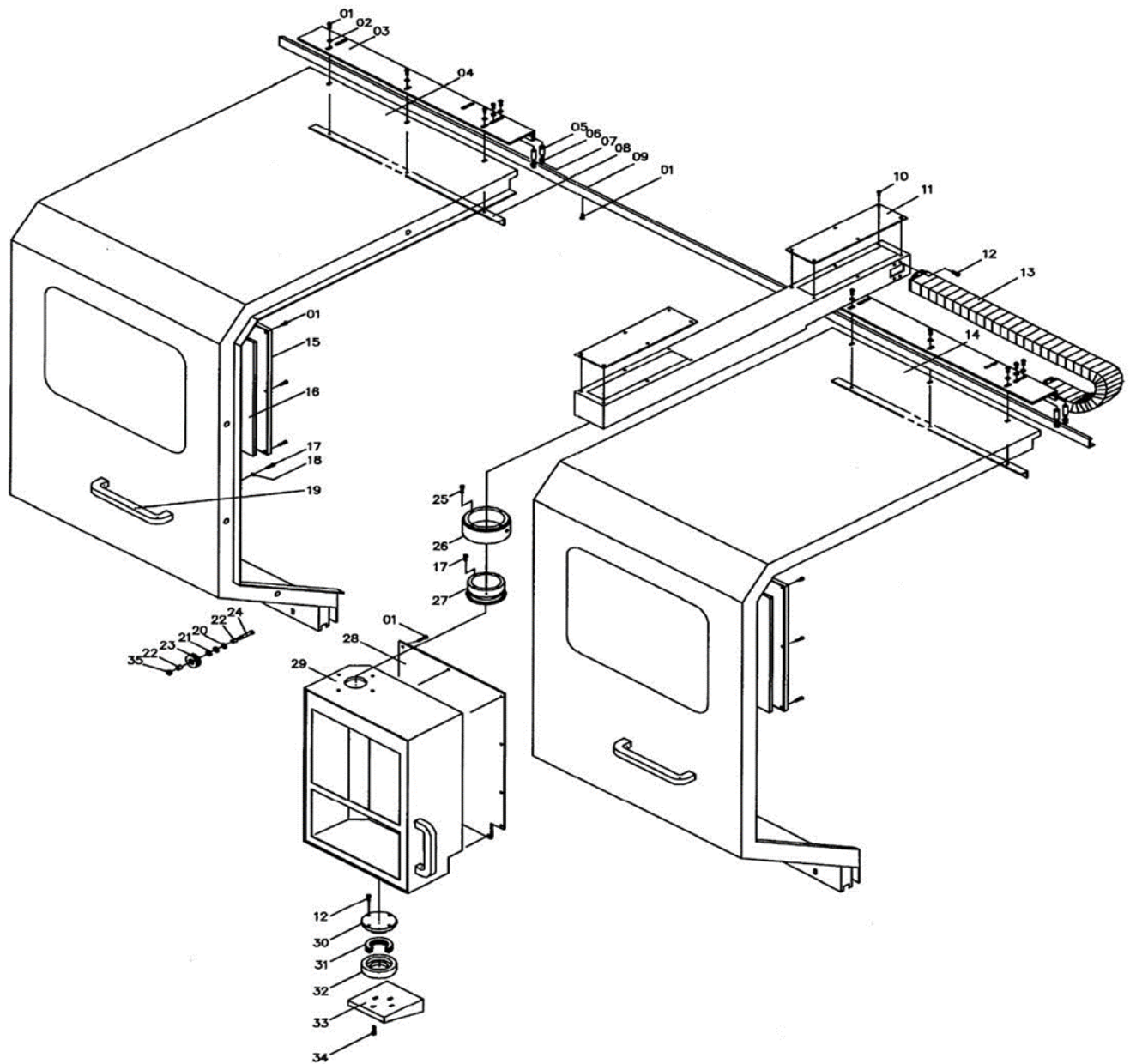

6.13 DOOR ASSEMBLY DRAWING & PARTS LIST

PARTS LIST				
REF NO.	PART NO.	DESCRIPTION	PARTS NAME	Q'TY
0 1		CAP SCREW	M6xP1.0x12L	4 0
0 2		WASHER	M6	6
0 3	26-70031	BRACKET		2
0 4	26-70006F	DOOR		1
0 5	26-70045	SHAFT		8
0 6		BEARING	6200,2Z	8
0 7		CLIP	ETW-6	8
0 8	26-70008	WIPER COVER		2
0 9	26-70012	GUIDE RAIL		1
1 0		CAP SCREW	M5xP0.8x10L	1 2
1 1	26-80029	PLATE		1
1 2		SCREW	M6xP1.0x12L	1 2
1 3		FLEXIBLE CARRIER	AB602200	1
1 4	26-70007F	DOOR		1
1 5	26-70009	COVER		2
1 6	26-70037	GLASS		2
1 7		SCREW	M8xP1.25x16L	8
1 8		WASHER	M8	2
1 9		HANDLE	7"	2
2 0		CLIP	RTW-22	4
2 1		BEARING	608,Z	8
2 2	30-70122	WASHER		8
2 3	26-70010	WHEEL		4
2 4	18-70011B	SHAFT		4
2 5		SCREW	M8xP1.25x35L	4
2 6	18-80032	BRACKET		1

6.14 TAILSTOCK ASSEMBLY (End View) DRAWING & PARTS LIST

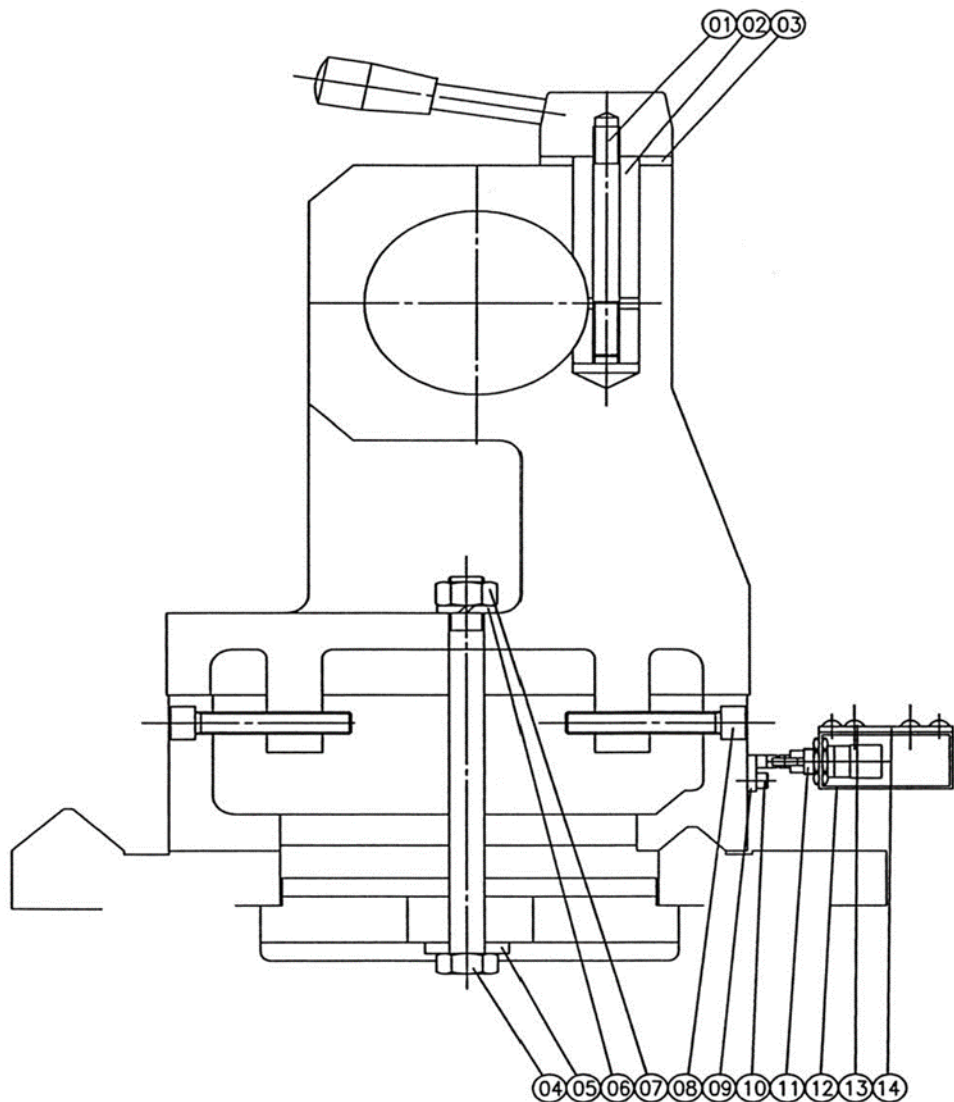

ET LARGE CAPACITY SERIES - TAILSTOCK END VIEW PARTS LIST

REF NO.	PART NO.	DESCRIPTION	PARTS NAME	Q'TY
1	26-60009	LOCATING BOLT		
2	26-60010	LOCATING NUT		
3		WASHER		
4		BOLT	M20xP2.5x225L	
5	26-60014	WASHER		
6		SPRING WASHER	M20	
7		NUT	M20	
8		SCREW	M12xP1.75x70L	
9	18-40033	DOG		
10		SCREW	M5xP0.8x12L	
11	BEN-2364	LIMIT SWITCH		
12	26-80022	BOX		
13		CAP SCREW	M5xP0.8x10L	
14	26-80023	COVER		

6.15 TAILSTOCK ASSEMBLY (Side View) DRAWING & PARTS LIST

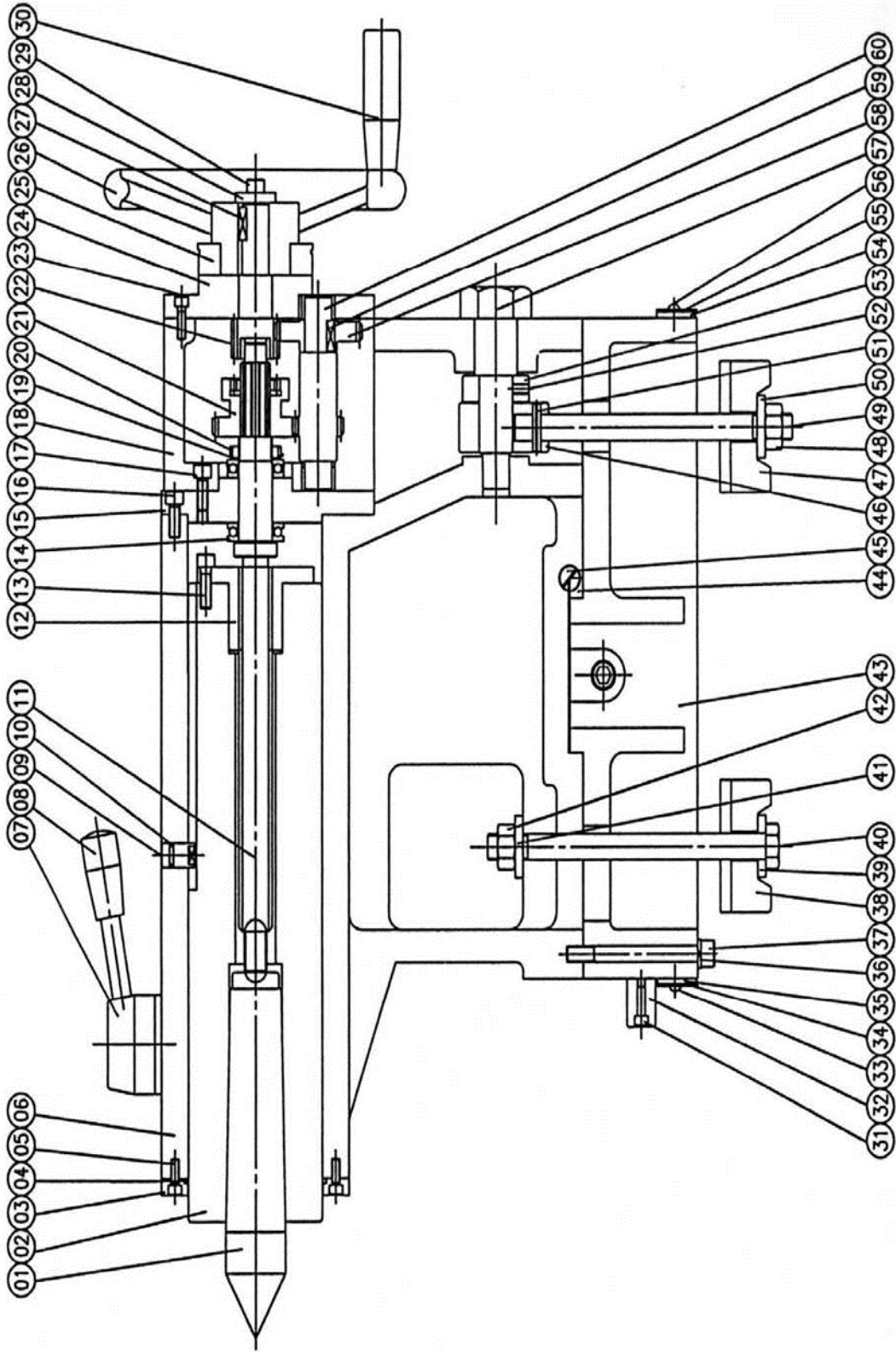

6.15 TAILSTOCK ASSEMBLY (Side View) DRAWING & PARTS LIST

ET LARGE CAPACITY - TAILSTOCK SIDE VIEW PARTS LIST

REF NO.	PART NO.	DESCRIPTION	PARTS NAME	Q'TY
1		CENTER	M.T.#5	
2	26-60003	QUILL		
3	26-60022	COVER		
4		O-RING	G-105	
5		SCREW	M6xP1.0x16L	
6	26-60001	TAIL STOCK		
7	26-60034	HANDLE BOSS		
8	26-60008	HANDLE		
9	26-60013	PAD		
10		O-RING		
11	26-60007	LEAD SCREW		
12	26-60006	NUT		
13		SCREW	M8xP1.25x25L	
14		BEARING		
15	26-60029	FLANGE BEARING		
16		SCREW	M8xP1.25x20L	
17		SCREW	M8xP1.25x20L	
18	26-60030	GEAR BOX		
19		WASHER	AW-05	
20		NUT	AN-05	
21	26-60031	GEAR		
22	26-60032	GEAR		
23		SCREW	M6xP1.0x20L	
24	26-60019	KEEP		
25	26-60020	INDEXING		
26	26-60005	HANDLE WHEEL		
27		KEY	6x6x20L	
28	26-60021	WASHER		
29		SCREW	M8xP1.25x20L	
30		HANDLE	M10	
31		SCREW	M6xP1.0x30L	
32	26-60028	STOPPER		
33		CAP SCREW	M5xP0.8x12L	
34	26-60025	WIPER COVER		
35	26-60024	WIPER		
36		SPRING WASHER	M10	
37		SCREW	M10xP1.5x130L	
38	26-60004	CLAMP PLATE		
39	26-60014	WASHER		
40		SCREW	M20xP2.5x225L	
41		WASHER	M20	
42		NUT	M20	
43	26-60002	BASE		
44	26-60016	GIB		
45	26-60023	SCREW		
46	26-60012	PIVOT BLOCK		
47	26-60004	CLAMP PLATE		
48		NUT	M20	
49	26-60011	BOLT		
50	26-60014	WASHER		
51		SPRING PIN		
52		SET SCREW	M6xP1.0x6L	
53	26-60018	COLLAR		
54	26-60026	WIPER		
55	26-60027	WIPER COVER		
56		CAP SCREW	M5xP0.8x12L	
57	26-60015	CAM SHAFT		
58	26-60036	GEAR		
59		KEY	6x6x18L	
60	26-60035	GEAR		